



APPLICATION FOR AN
Idaho Community Development Block Grant

by the

CITY OF SHELLEY

MARCH 6, 2020

Stacy Pascoe, Mayor of the City of Shelley

SHELLEY SENIOR CENTER



City of Shelley

Celebrating our 100th Anniversary

101 South Emerson Street Shelley, Idaho 83274 (208) 357-3390

City Web Site www.ci.shelley.id.us



MAYOR
Stacy Pascoe

COUNCIL
Earl Beattie
Jeff Kelley
Kim Westergard
Adam French

OFFICERS
Sandy Gaydusek
City Clerk/Treasurer

Red Mohler
Police Chief

Justin Johnson
Public Works Dir.

Mikel Anderson
Recreation Director

Forsgren Engineering
City Engineer

B.J. Driscoll
City Attorney

January 14, 2020

Director Tom Kealey
Idaho Department of Commerce
P.O. Box 83720
Boise, ID 83720-0093

Dear Director Kealey:

The City of Shelley respectfully submits this application for an Idaho Community Development Block Grant. The Shelley Senior Center ran out of funding during the first phase of construction, which remedied many urgent issues, but there are still items that need updated to make the center fully functional and safe for the aged population in Shelley and Bingham County.

The Shelley Senior Center delivers pivotal social, educational and nutritional services to older adults in Bingham County. The current facility is still not up to ADA standards, and the kitchen is in need of sanitary upgrades. The center also has the opportunity to become an emergency shelter for seniors during a time of disaster, but need additional funds to construct a safe environment for their patrons. They have \$15,000 in matching funds to help finance this project.

The upgrades to this facility will provide a safe environment for one of our most vulnerable populations.

We appreciate your time and attention to our CDBG request.

Sincerely,

Stacy Pascoe
Mayor, City of Shelley

Table of Contents:

	Page Number
1. Idaho Community Development Block Grant Application Information Form.....	5
2. Economic Advisory Council Page.....	6
3. Threshold Factors.....	7
a) Eligible Applicant.....	7
b) Eligible Activity.....	7
c) National Objective.....	7
d) Citizen Participation Plan and Hearing.....	7
e) Administrative Capacity.....	7
f) Fair Housing Resolution.....	8
g) Anti-displacement Plan.....	8
4. Program Income.....	8
5. Project Description.....	8
6. Budget Narrative.....	10
7. Budget Form.....	10
8. Detailed Cost Analysis.....	11
9. Project Schedule.....	11
10. Financial Profile.....	12
11. Project Site – Field Notes Review.....	14
12. Certifications.....	16
13. Review & Ranking Criteria	20

APPENDIX

EXHIBIT ONE: Citizen Participation

Citizen Participation Plan
Documentation of Publication
Handout
Minutes

EXHIBIT TWO: Procurement

Architect Solicitation Process
Minutes Hiring Architect
Administration Solicitation Process
Minutes Hiring Grant Administrator

EXHIBIT THREE: Fair Housing/ADA

Fair Housing Resolution
504/ADA Transition Plan
ADA Checklist Documentation

EXHIBIT FOUR: Drawings/Cost

Existing Layout
Proposed Layout
Cost Estimate
Generator

EXHIBIT FIVE: Senior Center

Articles of Incorporation
Board Member Roster
Deed to Building
Project Site Map – Explosive and Flammable Operations
Growth 2016-2019
Inspection Report
Activities
Outreach

EXHIBIT SIX: Match

CHC Grant
Completed Work in Past Year

EXHIBIT SEVEN: Financial

Balance Sheet 2017
Balance Sheet 2018
Balance Sheet 2019

EXHIBIT EIGHT: Letters of Support

Scott Reese, Emergency Management for Bingham County
Dale Clark, Hobbs Middle School Principal
Heather Bjornlie, ISU Student & Volunteer
Mike Spencer, American Legion Post 93
Elias Lopez, District Director of the Grand Teton Council of the Boy Scouts of America

ICDBG Application Information Form

Applicant: City of Shelley Chief Elected Official: Mayor Stacey Pascoe
 Address: 101 S. Emerson, Shelley Idaho 83272-1226 Phone: 208-357-3390
 Email Address: stacypascoe@cableone.net
 DUNS # 18-201-8960 CAGE Code 3RZD5

Sub recipient (if applicable): Shelley Senior Center Chief Elected Official: Ron Harada
 Address: 193 W. Pine Shelley, Idaho 83274 Phone: 208-569-2330

Application Prepared by: SICOG Phone: 208-233-4535 x 1
 Address: 214 East Center Pocatello ID 83201

Architect/Engineer/Planner (Contact Name): nw architects, p.a. Phone: 208-522-8779
 Address: 990 John Adams Parkway Idaho Falls, ID 83401

NATIONAL OBJECTIVE (MARK ONE)

LMI Area LMI Clientele Imminent Threat
 LMI Jobs Slum & Blight LMI Housing

PROJECT TYPE (MARK ONE)

Public Facility Imminent Threat
 Infrastructure for Jobs Senior Center
 Downtown Revitalize Public Park
 Community Center

PROJECT POPULATION TO BENEFIT (PERSONS): (Census/Survey/Clients/Jobs)

TOTAL # TO BENEFIT: _____ TOTAL # LMI TO BENEFIT: _____

% LMI TO BENEFIT: _____% Senior Center Clientele: automatic qualification

PROJECT DESCRIPTION: This project will upgrade the countertops in the service area of the kitchen, replace the kitchen island, replace an unusable cold storage locker with usable storage, do ADA upgrades in both restrooms, cut an additional door into the rear of the center, drop the ceiling in the kitchen, construct a janitorial closet, and install hand rails to the basement. Also add a shower to the bathroom and generator for use as an emergency shelter.

SOURCE	AMOUNT	FUNDS COMMITTED/ CONTRACT AWARD DATE	DOCUMENTATION IN APPENDIX **
ICDBG	200,000		
Local Cash**	6,426.26		
Local Loan			
Local In-Kind			
USDA-RD Grant			
State Grant			
Foundation Grant	15,000	November 19, 2019	6
Private Investment			
Other (identify)			
TOTAL PROJECT FINANCING	221,426.26		

Identify Loan Source(s) No Loan Date Bond or Necessary and Ordinary Passed NA

** Over the last year, the Senior Center has continued to improve their facility in the amount of \$1,426.26.

** The Senior Center signed a \$5,000 development contract with SICOG November 15, 2019.

Economic Advisory Council Page:

The Shelley Senior Center had a Phase 1 construction that rectified some of the emergent needs of the facility, but, due to bids that came in higher than expected; they were unable to complete the project to make the facility fully functional and safe for the senior population of Shelley and the surrounding areas.

Phase 1 construction was not able to address the Shelley Senior Center's need for ADA upgrades to their bathrooms, and they still need upgrades to the sink, grab bars, door knobs and coverage of exposed pipes that pose safety issues for the patrons of the facility. Kitchen surfaces are broken and not sanitary. Safety rails are needed on the basement steps for access to storage. The center needs a fire door at the rear of the building. All these items were listed as critical needs for the Shelley Senior Center. Employees and volunteers are also subject to negotiating an old cold storage locker that has a treacherous step, and this project would like to replace it with more usable storage for food service. Chemical storage was identified as an issue in Phase 1, and this phase would construct a new janitorial closet to store chemicals that are currently being stored haphazardly in public spaces. The janitorial closet would also provide a mop sink for staff to prevent them from filling mop buckets and dumping dirty water in the kitchen. The lighting in the kitchen continues to be an issue; the exposed bulbs are a critical safety issue.

The City of Shelley does not have a Red Cross identified emergency shelter, and it was suggested by emergency management that the Shelley Senior Center become an emergency shelter. Their familiarity in the community, ADA accessibility and ability to provide food service make them the logical choice in case of an emergent situation. This project proposes the addition of a shower and generator to make the project whole.

The Shelley Senior Center is a social necessity for the aged population in Bingham County. Lunch service is on Wednesdays and Fridays, but offer community classes and workshops throughout the week. In 2019, they served 5,940 congregate meals and 4,691 home delivered meals. Although it is a place for area seniors to gather for comradery, education and a healthy meal, it is more than just a place for lunch. It's a place for seniors to receive accurate, safe education and information about services available for them; anything from help with the 2020 Census to Fit and Fall classes provided by community partners. The aged population has the opportunity to learn new skills and have intergenerational interaction with youth in the area to teach service and volunteerism. The goal is to continue to provide a safe, functional and engaging environment for the people in Bingham County.



See Project Drawings Exhibit 4.

VI. **Threshold Factors**

A. **Eligible Applicant:**

The applicant is a city The applicant is a county

B. **Eligible Activities:**

This project will bring the Shelley Senior Center up to ADA compliance, address unsafe and unsanitary working conditions in the kitchen, provide safe storage of chemicals, and add features that will allow emergency shelter designation.

See Cost Estimate Exhibit 4.

C. **National Objective:** There are six National Objectives listed below. Complete only the National Objective that will be met with the project.

C.2. Low- and Moderate-Income Limited Clientele

D. **Citizen Participation:** *(respond to questions and provide documentation in Appendix)*

ICDBG Citizen Participation Plan adopted? X Yes ___ No

Did you hold a public hearing prior to application? Yes

Date of Notice January 03, 2020 Date of Hearing January 14, 2020.

See Exhibit 1

E. **Administrative Capacity:**

1. Applicant Capacity

- a. The City Clerk/Treasurer has been in the position for twenty seven years. The Clerk has a great relationship and history with SICOG and will be able to perform the requirements for meeting financial and other requirements for the project. The Senior Center Manager is well established and has full Board support. The City has a background in working with grants, funders and meeting regulations. The public works director has been in the position at the City for fourteen years.
- b. The most recent audited financial statements for the city are for the year of 2018 -2019 fiscal year. There were no material weaknesses or deficiencies. Sent to Idaho Department of Commerce on 02/14/2020.
- c. The most recent ICDBG grant was awarded in 2017 for a Water System Improvement Project. The applicant also managed a Senior Center Grant approximately 20 year ago.
- d. The Senior Center is the sub-recipient. They are governed by a board of directors and were last audited in 2017.

Articles of Incorporation and Board Roster are attached in Exhibit 5.

The Sub-recipient agreement will be completed with the Shelley Senior Center following a grant award.

2. **Grant Administrator.**

The City of Shelley has completed the process to procure a certified grant administrator. The micro-purchase procedure was used and the city voted to hire SICOG on January 14, 2020.

**Please see Exhibit 2 to view:
Administration Procurement Process
City Council Minutes**

F. Fair Housing:

See Fair Housing Resolution Exhibit 3

G. Anti-Displacement Resolution:

The Certification page covering this resolution is included in the application.

VII. Program Income:

There is no program income for the Senior Center. The Center brought in \$1,653 last year in catered meals. These funds are used to help run the center. The profit and loss statement attached shows the net income for the center last year was -\$22,478.

VIII. Project Description and Property

A. Project Description:

The Shelley Senior Center is in need of ADA compliance upgrades and functional upgrades to the kitchen and food storage areas. There is not a Red Cross Certified Emergency Shelter in Shelley, Idaho, and, because the Senior Center is a well utilized facility in the area, it is a reasonable facility to shelter in case of an emergency. This project will replace unsanitary counters and serving stations in the kitchen. It will remove inefficient and treacherous cold storage areas with usable space. This project will remodel bathrooms to bring them up to ADA compliance and add a shower for use in an emergency shelter capacity. They will add a storage closet for safe placement of chemicals and add a mop sink. They will add an egress door to the rear of the building for fire code compliance. The addition of handrails on the stairs to the basement will make it a safer place for employees and volunteers. Adding a generator will complete the requirements for becoming a safe place for seniors to go in case of emergency.

Layouts in Exhibit 4

This project will help a facility that is consistently providing more and more services to citizens be a safe and functional facility for the people of Bingham County. Congregate meals average 62 people, but another 50 are prepared to be delivered to the rural areas surrounding the center. The upgrades to the kitchen will make it a more streamline process for the staff to prepare and get meals to the seniors in need in the area. Any change in the numbers for service in the 2019 year was because of the Phase I construction disrupted service for the center in March and April.

Growth in Exhibit 5

B. Project Property & Permits: Answer the following questions and attach documentation.

1. Does the applicant have current ownership or title to property applicable to the project? Yes No

Deed in Exhibit 5

The City of Shelley is the owner of this building and the applicant.

2. Will any property be needed for this project? Yes No
Status of the purchase: _____
Estimated date of final purchase: _____
What funds will be used to make purchase? _____
3. Will any easements/or rights-of-way be needed for this project? Yes No
Status of the purchase: _____
Estimated date of final purchase: _____
What funds will be used to make purchase? _____
4. Will any lease be needed for this project? Yes No
Status of the lease: _____
Estimated date of lease execution: _____
5. Is anyone living on the land or in the structures at the proposed site? Yes No
6. Is any business being conducted on the land or in the structures at the proposed site? Yes No
7. Are there any businesses, individuals, or farms being displaced as a result of this project? Yes No
8. Are there permits that will be needed for the project, i.e.,
- well permit Yes No
 - water rights Yes No
 - land application Yes No
 - demolition permits Yes No
 - zoning permit Yes No
 - air quality permit Yes No
 - building permit Yes No
 - other () Yes No

Status of the permits (has application for the permit been submitted, if so what is projected date of issue?): City will probably waive the building permit. No other permits needed for this project.

9. Describe the ownership or lease arrangements for the property involved in the project. The building is owned by the City of Shelley for the benefit of the Senior Center.

Deed in Exhibit 5

IX. **Budget Narrative:** Describe the source and status of all funding for the project according to the instructions. Provide support documentation in the appendix.

A. Government

Idaho Community Development Block Grant is the only agency funding involved in this project.

B. Local

The Senior Center fundraises by selling baked goods and hosting other fundraisers. These local funds will pay for project development and grant writing. The Shelley Senior Center has also contributed \$1,426.26 in repairs related to the project in between the grant cycles.

C. Private

The Shelley Senior Center received a \$15,000 grant from the CHC Foundation to help with the cost of construction.

If applicable will the city/county/district allow Commerce staff to access RD apply?

_____ Yes _____ No X N/A

X. **Budget Form**

Line Items	ICDBG	Cash	In-Kind	Private	Total
Planning		\$5,000.00			
Administration	\$20,000				
Design Professional	\$10,000				
Construction	\$170,000	1,426.26		\$15,000	
Legal					
TOTAL COSTS	\$200,000	\$6,426.26		\$15,000	\$221,426.26

XI. **Detailed Cost Analysis**

1. Have plans and specs been submitted to regulatory agencies for review? ___Yes X No

If yes, list date submitted: _____
 If no, list expected date to be submitted: Preliminary drawings are available in Exhibit 4. Completed plans and specs will be prepared when funding is available.

2. Will project include bid alternatives to meet project budget if necessary? X Yes ___No

3. Are Davis Bacon wage rates applicable to the project? X Yes ___No

If yes, are they included in the project costs? X Yes ___No

4. Design Professional Cost Estimate may be found in **Exhibit 4.**

XII. Project Schedule

Project Activity	Date (to be) Completed	Documentation in Appendix
Design Professional Contract Executed	April 2020	
Grant Administration Contract Executed	April 2020	
Environmental Release	June 2020	
Bid Document Approval	September 2020	
Bid Opening	October 2020	
Construction Contract Executed	October 2020	
Start Construction	January 2021	
Second Public Hearing	January 2021	
Certificate of Substantial Completion	March 2021	
Update Fair Housing Plan	February 2021	
Update 504 Review and Transition Plan	January 2021	
LEP Four Factor Analysis	February 2021	
Construction 100% Complete	March 2021	
Final Closeout	March 2021	

In addition to the items above, include the following for Job Creation projects: NA

XIII. Grantee and Sub-recipient Financial Profiles

Is the Grantee a (circle one) City County

If a sub-recipient, what type of Organization (circle one)

- Water District Sewer District Water Association
- For-Profit Company Non-Profit Company Recreation District
- Fire District Hospital District Other (explain): Senior Center

The Shelley Senior Center is the Sub recipient for the grant which is sponsored by the City of Shelley.

**Section III. All Applicants except Sewer and Water:
Grantee or Sub-Recipient:**

- A. Does the organization have taxing authority? ___Yes XNo
 - 1. Do you tax? ___Yes XNo
 - a) If yes:
 - (1) What is the tax rate? _____
 - (2) What is the annual tax amount generated? _____
 - 2. If your organization does not tax, how are operational costs sustained? Examples: bonds, donations, assessments, etc.: Donations from visitors, meal assistance from Area Agency on Aging, County and City both make annual donations for the operation of the Senior Center.

Section IV. All Applicants

Furthering Fair Housing

As part of the CDBG program, cities and counties are required to further fair housing within your community. In 2016, Commerce and Idaho Housing and Finance Association conducted an assessment to fair housing. The assessment examined policies and practices among Idaho's cities, counties, and housing industry to determine fair housing issues and contributing factors.

For some of these contributing factors there are steps cities and counties can take to achieve the goal of reducing or mitigating the factors, thereby furthering fair housing.

Contributing Factor #1 - There is the lack of cities and counties providing for the allowance of group homes in designated residential zones or their narrow definitions of the types of group homes allowed (e.g., nursing and rest homes) Why is this a contributing factor? The regulation may treat residents who are disabled, differently. Therefore;

Has the City reviewed its zoning codes specific to group homes to ensure that they are in compliance with the Fair Housing Act? (group homes are allowed in residential zones and that the City definition of a group home is not too restrictive)

Yes No

If No, what steps are you taking to address the issue? Yes, the city has looked into this and found that there is a state code that they follow that a group home is a residence (includes disabled). Idaho Statute 67-6531

Contributing Factor #2 - Idaho's fair housing law does not provide protection based on familial status. Familial status is the presence of one or more children under the age of 18, pregnant woman, or someone in the process of acquiring legal custody of a child. Why is this a contributing factor? Residents who are unfamiliar with fair housing law may believe that they are not protected from housing discrimination based on familial status because Idaho's law does not cover familial status.

Does the City have an ordinance, resolution, or proclamation that prohibits discrimination against individuals based on their familial status? Note: this is not the same as the Fair Housing Resolution.

Yes No

If No, has the council or commission discussed the issue and/or are willing to pass such an ordinance, resolution, or proclamation? The Council has not discussed the issue but would be willing to consider an ordinance, resolution or proclamation.

Contributing Factor #3 – Lack of public transportation in rural areas. Also, insufficient transportation services to support independent and integrated community living for seniors and persons with disabilities.

In accordance with Idaho's Local Land Use Planning Act, has the City or County completed their Comprehensive Plan? Yes No

If Yes, when was the Plan last updated? 2015

Under the transportation component of the Plan has the City evaluated:

- Existing (or feasibility of) public transportation options such as – bus or van? ___ Yes X No
- Bicycle paths? X Yes ___ No

Contributing Factor #4 – Low wages in economically disadvantaged rural areas due to limited economic growth and growth in low wage industries (e.g. service jobs)

Does the City belong to an economic development organization whose objective is to advance job growth or training opportunities in the area? X Yes ___ No If yes, identify the organization(s) SICOG and REDI

Contributing Factor #5 – Housing in rural areas developed without visitable / accessible features due to limited development in some rural areas and when housing was developed.

What is the most current edition of the International Building Code the City has adopted?
2012

What is the most current edition of the International Residential Code the City has adopted?
2012

In addition to the International Residential Code, has the City adopted a building standard or ordinance that requires or encourages visitability in single family housing? (basic requirement: one zero-step entrance, doors with 32 inches of clear passage space, and one bathroom on the main floor you can get into in a wheelchair)

___ Yes X No

If Yes, identify when the ordinance or resolution was adopted.

XIV. Project Site – Field Notes Review

The purpose of this review is to identify potential environmental related issues that could delay, hamper or derail the proposed project. The information will assist in understanding what studies, documentation, and mitigation measures could be applicable in order to commence project construction.

1. Limitations on Activities

Is the Grantee planning or in the process of acquiring property for this proposed project?

___ Yes X No

If yes, is the Applicant aware that land acquired or site work after submission of the ICDBG application is subject to 24 CFR 58.22 Limitation on Activities Requiring Clearance? Meaning once an application for ICDBG funds is submitted, neither Applicant or sub recipient, may commit Non- HUD funds to a project for land acquisition or site work (except for minor testing) before the environmental review is complete, unless the land acquisition or contract is conditioned on completion of the ICDBG environmental review.

2. Historic Preservation

Has the SHPO or THPO been notified of the project? X Yes ___ No

Have tribes with possible cultural and religious sites been notified of the project? X Yes ___ No

3. Floodplain

Is the project located within a floodway or floodplain designated on a current FEMA map? Check Web site www.store.msc.fema.gov ___Yes ___No Not Sure

FEMA has not completed a study to determine flood hazard for the selected location; therefore, a flood map has not been published at this time.

If the project is located in a floodway or floodplain, is the community where the project is taking place a participant in the National Flood Insurance Program. Check Web site www.idwr.idaho.gov/water/flood Yes ___No

4. Wetlands

Are there ponds, marshes, bogs, swamps, drainage ways, streams, rivers, or other wetlands on or near the site? ___Yes No

If yes, has the Army Corps of Engineers (Corps) been notified? ___Yes ___No N/A

Has the Corps indicated what permit level will be required? ___Yes ___No N/A

5. Asbestos and/or Lead Based Paint

For building renovations, remodeling or demolition, has an asbestos analysis been planned for or conducted?

Yes ___No ___N/A Will contact before any flooring work.

For housing rehabilitation, has a lead based paint assessment been planned for or conducted? ___Yes ___No N/A

6. Noise Sensitive Use

Is the project new construction or rehabilitation of noise sensitive use (i.e., housing, mobile home parks, nursing homes, hospitals, and other uses where quiet is integral to the project functions)? ___Yes No

If yes, is the project located within 5 miles of an airport, 1000 feet of a major highway or busy road, or 3,000 feet of a railroad? ___Yes ___No N/A

7. Explosive and Flammable Operations

Is the physical structure (not necessarily infrastructure) intended for residential, institutional, recreational, commercial or industrial use? Yes ___No ___Unknown at this time

If yes, are there any above ground explosives, flammable fuels or chemical containers within one mile of the physical structure? Yes ___No

If yes, have you been able to identify what the container is holding and the container's size?

Yes ___No

The site is located in a commercial area within one mile of fuel stations.

Map in Exhibit 5

8. **Site or Soil Contamination**

Are there any known hazardous materials, contamination, chemicals, gases, and radioactive substance on or near the site? Yes No Unknown at this time

If yes, explain _____

During the visual inspection of the site, are there signs of distressed vegetation, vents or fill pipes, storage/oil tanks, stained soil, dumped material, questionable containers, foul or noxious odors, etc. Yes No

If yes, explain _____

At this time, are the site's previous uses known to have been gasoline stations, train depots, dry cleaners, agricultural operations, repair shops, landfill, etc.? Yes No

Are other funding agencies requiring the Grantee to perform an American Society for Testing Materials (ASTM) environmental assessment? ASTM assessment involves analysis of site uses and ownership, inspection of site, and possible testing. Yes No

9. **Other Agency Environmental Reviews**

Have facilities studies or other environmentally related site reviews been conducted or in the process of being conducted? Yes No

10. **Information Letters**

Scoping letters were sent out prior to the application for the Shelley Senior Center Phase I on February 26, 2018. Per Commerce, and because we are not making any exterior improvements, we did not resend letters.

Check the agencies that have been mailed an environmental information letter.

Note: If other funding agencies have sought comment, in writing, from the agencies listed below for the same project, you may not need to send an information letter. Contact your Specialist if other environmental information or scoping letters have been sent.

- Idaho State Historic Preservation Officer
- Tribal Historic Preservation Officer or Tribal Office
- Idaho Department of Water Resources – Local Regional Office
- Army Corps of Engineers (if wetlands are applicable)
- U.S. Fish and Wildlife
- NOAA Fisheries (if salmon and/or steelhead are applicable)
- Idaho Fish and Game
- USDA Natural Resource Conservation Service (if farmlands are applicable)
- Idaho Department of Environmental Quality
- Local Government – Planning Department
- Others _____

CERTIFICATIONS

I certify the data in this application is true and correct, that this document has been duly authorized by the governing body of the City of Shelley and we will comply with the following laws and regulations if this application is approved and selected for funding.

Specific CDBG Provisions:

Section 110 of the Housing and Community Development Act of 1974, as amended, by the Housing and Urban-Rural Recovery Act of 1983 and the Housing and Community Development Act of 1987, 24 CFR 570.603, and State regulations regarding the administration and enforcement of labor standards;

It will comply with all parts of Title I of the Housing and Community Development Act of 1974, as amended, which have not been cited previously as well as with other applicable laws;

Conduct and administer its program in conformance with Title VI and Title VIII, and affirmatively further fair housing;

Provide opportunities for citizen participation comparable to the state's requirements (those described in Section 104(a) of the Act, as amended);

Not use assessments or fees to recover the capital costs of CDBG funded public improvements from low and moderate income owner occupants;

Minimize displacement as a result of activities assisted with CDBG funds by following the Idaho Department of Commerce's anti-displacement and relocation assistance plan and the Uniform Relocation Assistance and Real Property Acquisition Act of 1970, as amended (49 CFR Part 24);

Policy on the Prohibition of the Use of Excessive Force:

It hereby prohibits any law enforcement agency operating within its jurisdiction from using excessive force against any individuals engaged in nonviolent civil rights demonstrations. In addition, it hereby agrees to enforce any applicable state or local laws against physically barring entrances or exits from a facility or location that is the subject of a non-violent protest demonstration.

It further pledges enforcement of this policy within its jurisdiction and encourages any individual or group who feels that it has not complied with this policy to file a complaint.

Civil Rights and Equal Opportunity Provisions:

Title VI of the Civil Rights Act of 1964 (Public Law 88-352), and the regulations issued pursuant thereto (24 CFR Part 1), which provides that no person in the United State shall on the grounds of race, color, or national origin, be excluded from participation in, be denied the benefits of, or be otherwise subject to discrimination under any program or activity for which the applicant received Federal financial assistance and will immediately take any measures necessary to effectuate this assurance. If any real property or structure thereon is provided or improved with the aid of Federal financial assistance extended to the applicant, this assurance shall obligate the applicant, or in the case of any transfer of such property, any transferee, for the period during which the real property or structure is used for a purpose for which Federal financial assistance is extended, or for another purpose involving the provision of similar services or benefits;

The Fair Housing Act (previously known as Title VIII of the Civil Rights Act of 1968) (Public Law 90-284), as amended, administering all programs and activities relating to housing and community development in a manner to affirmatively further fair housing in the sale or rental of housing, the financing of housing, and the provision of brokerage services;

Section 109 of Title I of the Housing and Community Development Act of 1987, as amended, and the regulations issued pursuant thereto (24 CFR 570.602), which provides that no person in the United States shall, on the grounds of race, color, national origin, religion, or sex, be excluded from participation in, be denied the benefits of, or be subjected to discrimination on the basis of age under the Age Discrimination Act of 1975 or with respect to otherwise qualified handicapped individuals as provided in Section 504 of the Rehabilitation Act of 1973 shall also apply to any such program activity;

Executive Order 11063, as amended by Executive Order 12259 on equal opportunity in housing and non-discrimination in the sale or rental of housing built with Federal assistance, and requiring that programs and activities relating to housing and urban development be administered in a manner affirmatively to further the goals of Title VIII of the Civil Rights Act of 1968;

Executive Order 11246 as amended by Executive Order 11375 and 12086, and the regulations issued pursuant hereto (24 CFR Chapter 60), which provides that no person shall be discriminated against on the basis of race, color, religion, sex or national origin in all phases of employment during the performance of Federal or federally assisted construction contracts. Contractors and subcontracts on Federal and federally assisted construction contracts shall take affirmative action to insure fair treatment in employment, upgrading, demotion, or transfer; recruitment or recruitment advertising; layoff or termination; rates of pay or other forms of compensation and selection for training and apprenticeship;

It will comply with Section 3 of the Housing and Urban Development Act of 1968, as amended, requiring that to the greatest extent feasible opportunities for training and employment be given to lower income residents of the project area and contracts for work in connection with the project be awarded to eligible business concerns which are located in, or owned in substantial part by, persons residing within the unit of local government;

Property Acquisition Provision:

It will comply with the Uniform Relocation Assistance and Real Property Acquisition Policies Act of 1970, as amended, and Federal implementing regulation at 49 CFR Part 24, and the requirements of section 570.496a and it is following a residential anti-displacement and relocation assistance plan under section 104(d) of Title I of the Housing & Community Development Act of 1974, as amended;

Environmental Standards and Provisions:

Its chief executive official:

- 1) Consents to assume the status of a responsible Federal official under the National Environmental Policy Act of 1969 (NEPA) (42 U.S.C. S 4321 et seq.) and other provisions of Federal law, as specified at 24 CFR 58.1 (a) (3) and (a) (4), which further the purposes of NEPA insofar as the provisions of such Federal law apply to the Idaho Community Development Block Grant Program; and
- 2) Is authorized and consents on behalf of the applicant and himself/herself to accept the jurisdiction of the Federal courts for the purpose of enforcement of his/her responsibilities as such an official.

It will comply with:

- 1) The National Environmental Policy Act of 1969 (42 U.S.C. S 4321 et seq.) and 24 CFR Part 58, and in connection with its performance of environmental assessments under the National Environmental Policy Act of 1969, comply with Section 106 of the National Historic Preservation Act of 1966 (16 U.S.C. 470), Executive Order 11593, and the Preservation of Archaeological and Historical Data Act of 1966 (U.S.C. 469a-1, et seq.) by:
 - a) Consulting with the State Historic Preservation Officer to identify properties listed in or eligible for inclusion in the National Register of Historic Places that are subject to adverse effects (see 36 CFR Part 800.8) by the proposed activity; and

- b) Complying with all requirements established by the State and to avoid or mitigate adverse effects upon such properties.
- 2) Executive Order 11988, Floodplain Management;
 - 3) Executive Order 11990, Protection of Wetlands;
 - 4) Endangered Species Act of 1973, as amended, (16 U.S.C. Section 1531 et seq.);
 - 5) The Fish and Wildlife Coordination Act of 1958, as amended, (16 U.S.C. Section 661 et seq.);
 - 6) The Wild and Scenic Rivers Act of 1968, as amended, (16 U.S.C. Section 1271);
 - 7) The Safe Drinking Water Act of 1974, as amended, (42 U.S.C. Section 300f et seq.);
 - 8) Section 401(f) of the Lead-Based Paint Poisoning Prevention Act, as amended, (42 U.S.C. Section 4831 (b));
 - 9) The Clean Air Act of 1970, as amended, (42 U.S.C. Section 7401 et seq.);
 - 10) The Federal Water Pollution Control Act of 1972, as amended, (33 U.S.C. Section 1251 et seq.);
 - 11) The Clean Water Act of 1977 (Public Law 95-217); and
 - 12) The Solid Waste Disposal Act, as amended by the Resource Conservation and Recovery Act of 1976 (42 U.S.C. Section 6901 et. seq.);
 - 13) Section 202(a) of the Flood Disaster Protection Act of 1973 (42 U.S.C. 4106) as it relates to the mandatory purchase of flood insurance for special flood hazard areas.

Labor Standards and Provisions:

The provisions of the Davis-Bacon Act (46 U.S.C. S 276a-5) with respect to prevailing wage rates (except for projects for rehabilitation of residential properties of fewer than eight units);

Contract Work Hours and Safety Standards Act of 1962, 40 U.S.C. 327-332, requiring that mechanics and laborers (including watchmen and guards) employed on federally assisted contracts be paid wages of not less than one and one-half times their basic wage rates for all hours worked in excess of forty in a work-week;

Federal Fair Labor Standards Act, 29 U.S.C. S 102 et seq., requiring that covered employees be paid at least the minimum prescribed wage, and also that they be paid one and one-half times their basic wage rate for all hours worked in excess of the prescribed work-week;

Anti-kickback (Copeland) Act of 1934, 18 U.S.C. S 874 and 40 U.S.C. S 276c, which outlaws and prescribes penalties for "kickbacks" of wages in federally financed or assisted construction activities;

Anti-Lobbying Certification:

No federal appropriated funds have been paid or will be paid, by or on behalf of the undersigned to any person for influencing or attempting to influence an officer or employee of any federal agency, a member of, employee of a member of, officer of or employee of Congress in connection with the awarding of any federal contract, the making of any federal grant or loan, the entering into any cooperative agreement and the extension, renewal, modification or amendment of any federal contract, grant, loan or cooperative agreement.

If any funds other than federal appropriated funds have been paid or will be paid to any person for influencing or attempting to influence an officer or employee of any federal agency, a member of, employee of a member of, officer of or employee of Congress in connection with this federal grant, the undersigned shall complete and submit Standard Form-LLL, "Disclosure Form to Report Lobbying," in accordance with its instructions.

The applicant shall require that the language of this certification be included in the award documents for all subawards at all tiers (including subcontracts, subgrants, and contracts under grants, loans, and cooperative agreements) and that all subrecipients shall certify and disclose accordingly. This certification is a material representation of fact upon which reliance was place when this transaction was made or entered into. Submission of this certification is a prerequisite for making or entering into this

transaction imposed by Section 1352, Title 31, US Code. Any person who fails to file the required certification shall be subject to a civil penalty of not less than \$10,000 and not more than \$100,000 for each such failure.

Administrative and Financial Provisions:

2 CFR Part 200, Uniform Administrative Requirements, Cost Principles, and Audit Requirements for Federal Awards

Miscellaneous:

It will establish safeguards to prohibit employees from using positions for a purpose that is or gives the appearance of being motivated by a desire for private gain for themselves or others, particularly those with whom they have family, business or other ties;

It will comply with the provisions of the Hatch Act, which limits the political activity of employees;

It will give State, HUD and the Comptroller General through any authorized representatives, access to and the right to examine all records, books, papers, or documents related to the grant; and

The local government hereby certifies that it will comply with the above stated assurances.



Stacey Pascoe

1-28-2020

Date

stacy pascoe

Printed Name

Chapter 7: Senior and Community Centers

- I. **Physical Conditions and Building Assessment (350 points):** Points will be awarded to each application based upon the center's documented needs.

A. **Facility / Building Assessment (100 points)**

1. For an existing facility the following should be conducted or assessed (100 points):

Preliminary Report

- a. **Information on the size, age, condition, adequacy, and suitability for continued use.**

The Building was built in 1958 and was remodeled in 1989. It is over 5,700 square feet and most of the building condition is good. The building can accommodate an occupancy of 252 people. The outside of the building is in good shape for its current use.

The 60 year old building was originally a grocery store. The kitchen work area is not adequate and has a lot of unusable space, and, although the first phase of construction remedied much of the urgent needs, there are still improvements that need to be made to make the center fully functional and safe for staff and volunteers.

The doors and windows are in good shape. There should be tempered glass placed in the inside office window.

There are no structure problems with the building. It is in good condition.

The office area has a slope that does not appear to meet ADA regulations. The slope is too steep. Patrons do not need access to this area.

A curb cut is not ADA compliant. That can be addressed when the city does sidewalk work again.

Critical Problems

The restrooms need critical improvements to meet ADA compliance. The current layout is not up to code.

The building has a fire safety issue with only one entrance/exit accessible by the community users. An emergency exit is needed at the back of the building due to its size and capacity.

Staff is using an ancient cold storage closet to store items used for service that is no longer in use as a freezer but is still in the work space. The old locker is bulky, awkward and not fully useful for the center's purposes. The workers store dry goods in this old locker which takes up much more space than is needed for the storage. There is a big step up into the locker that is unsafe and a trip hazard. This kitchen has some work flow issues that impede staff. Food prep surfaces

are dated, broken and not sanitary for the amount of food service the center provides.

The lighting in the kitchen is a problem and out of compliance with Idaho Food Code. The lighting tubes are open and exposed and could be broken. If broken the glass could come raining down on the workers and on the food. There are also exposed beams.

Storage is inadequate. The construction of a separate janitorial closet will prevent the staff from having to store chemicals in the basement or bathrooms. It will all keep the staff from having to fill mop buckets in the kitchen and then dump the used water in kitchen drains.

Another grab rail is needed for the basement access stairs. The facility is using the basement for storage.

To be designated as the only emergency shelter in Shelley, the facility will need the addition of a shower in one of the bathrooms and a generator.

- b. Inspection or observation reports by local building officials, public works staff, design professional, or contractors (identify safety/health concerns, violations of codes or standards, if any).

Health Inspection Report Exhibit 5.

- c. ADA assessments of the building and site.
An ADA assessment was conducted January 23, 2018, and no ADA upgrades were completed in Phase I construction.

ADA Report Exhibit 3.

- d. Energy audits of the building.
None
- e. When necessary, any environmental reports such as asbestos and lead-based paint testing, an ASTM Phase I (if acquiring a facility), or other reports.

The project may require an asbestos inspection if the flooring is disturbed.

- f. Photographs of the facility are included below.

- B. Senior or Community Center:** Identify the problems or needs of the facility. Check the building components as **critical, urgent, potential concern** or **no problems**. Document below why a component is considered critical (violation of building or health codes or safety concerns), urgent (health and safety problems), or potential concern (end of useful life). (250 points)

Criticalness and Urgency of Problems

Problem or Need Rating				
Identification of Problem	Critical (9) (insert √)	Urgent (5) (insert √)	Potential Concern (1) (insert √)	Reviewed No Problems (insert √)
Physical Conditions:				
Roof (1989)				√
Walls				√
Foundation				√
Floors		√		
Weatherization		√		
Expansion				√
Other:				
New Center				
Interior Problems:				
Asbestos/lead based paint				√
Restrooms	√			
Electrical/plumbing/lighting				√ (Phase 1)
Heating/air conditioning			√	
Fire safety	√			
Unusable space	√			
Other: Kitchen lighting	√			
New Center				
Kitchen and Food Storage:				
Health inspection				√
Capacity of dry storage	√			
Capacity of cold storage				√
Equipment				√
Other: Chemical storage	√			
New Center				
Access for Persons w/Disabilities				
Parking			√	
Entry				√
Restrooms	√			
2 nd Floor Access				√
Other:				
New Center				
Subtotals	63	10	2	

Identify why any component considered critical or urgent is such. Provide photos when possible:

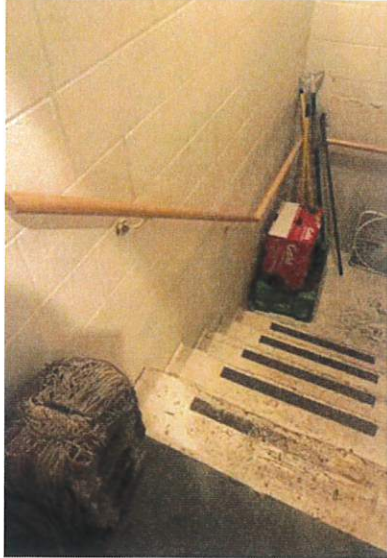

Basement Access

Handrail to the basement needs replaced for safety of employees and volunteers.

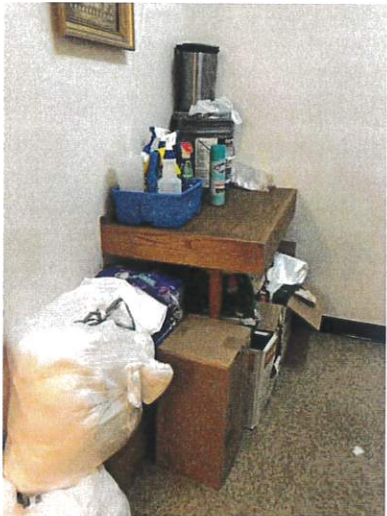

Safety Issues

According to the CDC, chemical should not be stored on the floor or in traffic areas. Additionally, toxic materials should be locked in dedicated storage.

Currently chemicals are being stored in the women's bathroom in the open. Construction of a janitorial closet will allow for chemicals to be stored securely. It will keep the bathroom clear of hazards, and an addition of a mop sink will keep the staff from filling and emptying mop buckets in the kitchen.





Bathrooms

Bathrooms are in need of ADA Upgrades.
ADA Standard 4.19.4: Exposed Pipes

Faucets cannot be operated without tight grasping, pinching or twisting of the wrist.
ADA Standard 4.27.4

Paper towel dispensers are placed higher than the ADA requirement of less than 48 inches.

Grab bars are not in correct position.
ADA Standard 4.26: Grab Bars

Door is not equipped with hardware that is operable with one hand and requires tight grasping, pinching and twisting of the wrist to open.

ADA Standard 4.13.9: Door Hardware

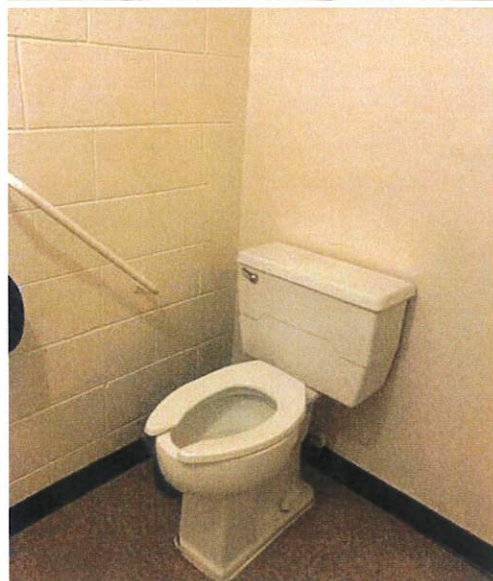
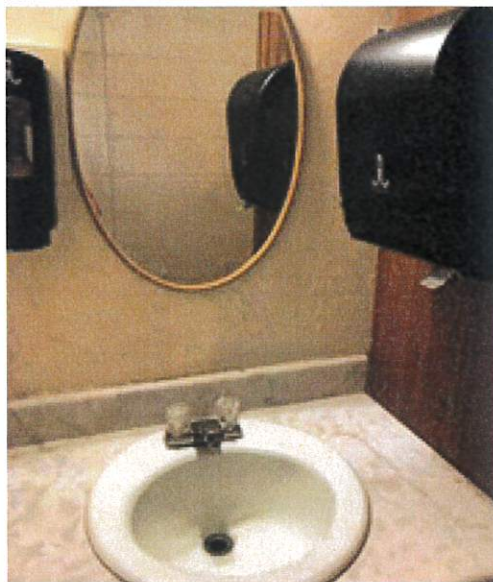



International Fire Code [BE] 10062.1 requires two exits for a facility of this size and max occupancy.

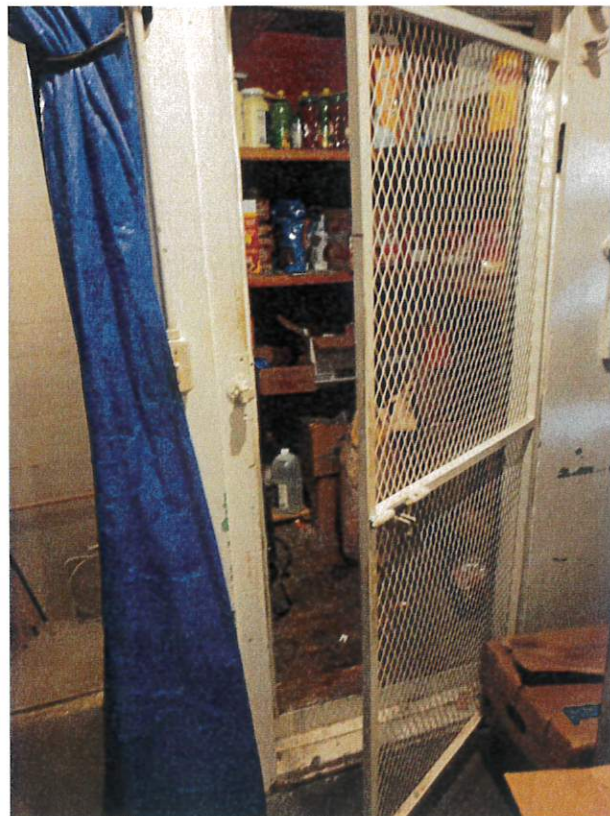

Kitchen

Ancient cold storage lockers are being used for storage but are a trip hazard and have a lot of wasted space.





Counters and serving areas in the kitchen are old, broken and unsanitary.

According to Idaho Food Code 4-202.11, food contact surfaces should be smooth, free of breaks, seams, cracks, chips, inclusions, pits and similar imperfections.



Food service areas are in need of upgrades for sanitary purposes. Idaho Food Code 4-202.17 says that Non food contact surfaces shall be free of unnecessary ledges, projections, and crevices, and designed and constructed to allow easy cleaning and to facilitate maintenance.



Lighting in the kitchen does not have any safety features, and, if broken, would rain glass on staff, volunteers and food.

Idaho Food Code 6-202.11 states that light bulbs shall be shielded, coated or otherwise shatter-resistant in areas where there is exposed food, clean equipment, utensils and linens; or unwrapped single service and single use articles.

II. **Project Implementation (200 points).** Using the categories below, the applicant must describe and document the process used to plan and implement the project and describe the components of the project.

1. **Planning (40 points).** Respond to the following questions.

Explain expected form of procurement for construction. (Examples: single bid, construction management, design build, owner build, or other)

This project will involve competitive bidding for a single construction contract with the architecture firm acting as the construction manager. Design professionals will work with the grantee to prepare bid documents, and will make those available via formal advertisement to qualified contractors.

Has there been any site plans, schematics, or sketches prepared for the project?

Yes No

See Exhibit 4.

What energy efficiency considerations and operating cost savings are incorporated into the project? (Examples: LEED and/or Energy Star design criteria)

Energy efficient lighting will be used to replace the dangerous lighting kitchen lighting.

List of work that has been completed on the facility in the last year.
(Example: patched leaking roof – August 2011)

See Exhibit 6.

2. **Design Professional (20 points):**

Option 1: To receive points the applicant must have completed the design professional selection process using procurement requirements as described in the most recent Grant Administration Manual.

The architectural cost of this project is under \$25,000. The Micro Purchase Procedure was used to secure an architect for the project.

The architect, nbw architects, p.a., were part of the Phase One development of the Shelley Senior Center, and, because of their familiarity with the project, they were hired again by the Shelley Senior Center as part of Phase Two. It was a unanimous vote by the Shelley Senior Center Board of Directors on January 24th, 2020.

See Exhibit 2.

3. **Grant Administration (20 points):**

The Grant Administration cost of this project is under \$25,000. The Micro Purchase Procedure was used to secure an administrator to provide the administration services for the project.

The potential grantee selected SICOG as the administrator for this grant unanimously at their City Council Meeting on January 14th, 2020.

See Exhibit 2.

4. **Schedule (5 points):** Points will be awarded based on the project schedule completed in the general application.

See completed project schedule on page 12

5. **Project Site – Field Notes Review (10 points):** Maximum points will be awarded if the applicant has completed the field notes review and mailed out environmental information request letters before submission of application.

See completed project schedule on page 15

6. **Property acquisition (20 points):** Points will be awarded if the applicant or sub recipient has site control, that is, that the applicant or sub recipient has ownership of the property including easements or right of way permits or has an option to purchase pending completion of the environmental release.

See copy of Deed in Exhibit 5

7. **Cost analysis (20 points):** The detailed cost analysis sheet should be completed and dated/signed within four weeks of submission of application.

See Exhibit 4

See cost analysis on page 11

8. **Applicant administrative capacity (65 points):** Points will be awarded based on:

- a. The applicant's grant project track record and the general ability of the city or county. Department staff may review financial audit reports, staff turnover, and recall elections to help make a determination. If sub-recipient, provide description of the agency's governing structure or framework such as nonprofit corporation, district, or association and the board composition. (25 points)

See Exhibit 5

See the governing board of the Senior Center and administrative capacity on page 8.

- b. Has the applicant completed an ADA/Section 504 self-assessment of the accessibility of its public programs and facilities and also completed a Transition Plan? (5 points) Yes No

See Exhibit 3

- c. Affirmatively Furthering Fair Housing (10 points):

See Exhibit 3

- d. Provide an operating income statement pro forma for the facility (revenue/expenses) for two years designating income sources operating cost (include: staff, insurance, utilities, maintenance, reserves for repair and replacement, etc.) (15 points)

See Exhibit 7

- e. Does the sub recipient have unrestricted cash reserves in the amount of at least 5% of estimated construction cost to cover unforeseen expenses such as higher than expected bids or necessary change orders? This cash reserve is in addition to contingencies in the cost estimate and cash match committed to the project in the budget. This can be in the form of a line of credit, a loan commitment, or a cash commitment from the applicant. (10 points)
 Yes No

If no, what changes to the scope of work is the sub recipient prepared to make to reduce the project cost by at least 10%?

The Senior Center will work with the Construction Manager help identify these changes.

III. Benefits (150 points)

Activities provided (100 points):

List the number and frequency of activities and services the center is providing to seniors, the neighborhood and the community on a monthly basis. Applicants should include activities and services such as health, recreation, nutrition, educational and transportation programs. Put a check mark (√) to indicate if the activity exists or is proposed.

Senior/Community Center Activities

Activity	Existing Activity (insert: √)	Proposed Activity (insert: √)	No. of Days Offered Per Month or Year*	Facilitated By
Health				
Nutrition Education	√		Twice a mo.	Shelley Area Senior Citizens, Inc
Blood Pressure Checks	√		Twice a mo.	Shelley Area Senior Citizens, Inc
Fit & Fall Proof Exercise	√		8 times a mo.	S.E. Idaho Public Health
Foot Clinic	√		Once a month	Blackfoot Home Health
Health Fair	√		Once a year	Bingham Memorial Hospital

Recreation				
Pinochle	√		4 times a mo.	Shelley Area Senior Citizens, Inc
Bingo	√		4 times a mo.	Shelley Area Senior Citizens, Inc
Dominos	√		4 times a mo.	Shelley Area Senior Citizens, Inc
Craft Days	√		5 days a year	Shelley Area Senior Citizens, Inc
Technology Workshops	√		5 days a year	Shelley Area Senior Citizens, Inc
Transportation	√		4 times a mo.	Shelley Area Senior Citizens, Inc
Group Trips	√		Once a month	Shelley Area Senior Citizens, Inc
Art Class	√		4 times a mo.	Heather Bjornlie/ISU Volunteer
Christmas Concert	√		Once a year	Various Artists/SA Senior Cit. Inc
Meals (home delivery/@Center				
Home Delivered	√		103 times a yr	Shelley Area Senior Citizens, Inc
Congregate	√		103 times a yr	Shelley Area Senior Citizens, Inc
Take Home/Bakery	√		103 times a yr	Shelley Area Senior Citizens, Inc
Other				
Trivia	√		4 times a mo.	Shelley Area Senior Citizens, Inc
Book Club	√		2 times a mo.	Shelley Area Senior Citizens, Inc
Clothing Exchange	√		Once a year	Shelley Area Senior Citizens, Inc
Spud Days Event	√		3 days a year	Shelley Area Senior Citizens, Inc
Live Entertainment	√		2 times a mo.	Various Artists/SA Senior Cit. Inc
Spaghetti Fundraiser	√		Once a year	Shelley Area Senior Citizens, Inc
Pet Love Project	√		4 times a mo.	Shelley Area Senior Citizens, Inc
Totals	24		73 month	
This facility is open to the seniors/community <u>200</u> days per year				

Activities Continued: See Exhibit 5.

If facility provides meals identify number of:

- a. Congregate meals served monthly/annually
 - Average monthly meals in 2018: 557
 - Average monthly meals in 2019: 495
 - Center was closed for renovation in 2019.
 - Annual meals served in 2018: 6,682
 - Annual meals served in 2019: 5,940
- b. Home Delivered/Frozen Meals monthly/annually
 - Average monthly meals in 2018: 466
 - Average monthly meals in 2019: 430
 - Center was closed for renovation in 2019.
 - Annual meals served in 2018: 5,588
 - Annual meals served in 2019: 4,691

See Exhibit 5 for Growth in Meal Service

2. Outreach (50 points). Describe the center's existing and/or proposed affirmative marketing and outreach efforts aimed at including participation by low-and-moderate-income persons, racial and ethnic minorities, disabled persons and non-English speakers. Examples might include: website, social media, postings, radio, television, outdoor signage, etc.

See Exhibit 5 for Outreach Examples

The Shelley Senior Center has a very active social media presence and website. They have two part time outreach employees who drive seniors to their appointments and to run errands. They organize and transport citizens on day trips to area attractions, write personal birthday cards, and compose and send over 300 newsletters every month. The staff and volunteers of the Shelley Senior Center are well known in the community and talk to community partners for referrals.

IV. **Project Local Match (100 points):** Measures the amount of cash and in-kind donations that are committed to just the CDBG project. A commitment letter must be provided in the appendix. If local match is a bond, the applicant must provide documentation that the bond has passed and who will buy it. The CDBG project can include prior planning, design, and property acquisition.

A. **Project cash match (60 points):** This criterion measures the percentage of cash matching funds committed to the ICDBG project. It is direct matching funds to just the ICDBG project. "Cash match" includes cash on hand, bonds, revolving loan funds, urban renewal funds, or resort city tax.

See Exhibit 6.

B. **Project in-kind match (40 points):** This measures the percentage of in-kind funds committed to the project which includes in-kind activities, force account work, volunteer work, donations, or waiving of fees to fund the ICDBG project. It is in-kind match to just the ICDBG project. No in-kind match for this project.

EXHIBIT ONE: Citizen Participation



Citizen Participation Plan
Documentation of Publication
Handout
Minutes

**Idaho Community Development Block Grant
(CDBG) Citizen Participation Plan**

City of Shelley

Pursuant to citizen participation requirements for Idaho Community Block Grant participants, the City of Shelley hereby certifies the following activities will be completed:

Provide for and encourage citizen participation, particularly for low and moderate income persons who reside in slum or blighted areas and areas in which CDBG funds are proposed to be used. Provide technical assistance to group's representative of low and moderate income persons that request assistance in developing proposals in accordance with procedures developed by the department. Such assistance need not include providing funds to such groups.

Hold a minimum of two public hearings, each at a different stage of the program, for the purpose of obtaining citizens' views. The first public hearing shall include a description of the proposed project, scope of work, budget, schedule, location, and beneficiaries. Any earned program income must also be noted. The application, related documents, and the Application Handbook shall be available for citizens to review.

The second public hearing on the status of funded activities and accomplishments to date; a general description of remaining work and a general description of changes made to the CDBG project scope of work, budget, schedule, location or beneficiaries.

A public hearing shall also be held in the event CDBG project activities are added, deleted or substantially changed from the application. Substantially changed means changes made in terms or purpose, scope, location or beneficiaries as defined by the CDBG program.

Provide reasonable and timely access to local meetings, information and records pertaining to the local government's proposed and actual use of CDBG funds. Public hearings shall be conducted at times and locations convenient to local citizens.

Public hearings shall be advertised in a local newspaper no less than seven (7) twenty-four (24) hour days prior to the hearing date. If there is no local newspaper, public notification will occur through some other method where there is wide distribution to citizens within the project area. The Community Development staff must approve this method.

A copy of the publication and/or affidavit of publication shall be submitted to the department. The notice should identify all of the topics to be addressed in the public hearing including the assurances that hearings shall be held in facilities that are accessible to persons with disabilities and that alternative formats shall be available to persons with disabilities where practicable, and with advance notice to the unit of local government.

Citizens shall also be notified they will be given the opportunity to comment orally or in writing at a minimum of one week prior to and at the hearing. Special accommodations shall be available for persons with disabilities who may wish to comment within this period.

Public hearings shall be conducted in a manner to meet the needs of non-English speaking residents where a significant number of non-English speaking residents can be expected to participate.

Local citizen participation records which shall be made available to the state and local citizens shall include: A copy of the public notice and/or affidavit of publication which describes proposed or actual project activities, scope of work, location, budget, schedule, objectives, and beneficiaries. Notices shall also contain the accessibility clause for persons with disabilities.

Grantees must provide the address, telephone number, and times for submitting complaints and grievances, and provide timely written answers to written complaints and grievances within fifteen (15) working days where practicable.

Local staff shall be familiar with citizen's complaint procedures. These procedures shall provide local citizens with the opportunity to protest project activities or related issues. A written complaint or grievance is formal notification of a concern, allegation or protest to a proper authority. A formal complaint will be considered filed at the time it is delivered to the appropriate authority's office. To file a complaint, citizens must provide enough information to allow an investigation. The complaint should be clear and concise and include the following information:

- A. Identification of the project, project location, and program activities.
- B. Reason for the complaint (hearsay and innuendo will not be considered valid).
- C. Sufficient data to substantiate any claims or charges. If possible, supporting documentation should be included.
- D. If desired, citizens may propose a solution to the problem.

If the complaint is concerning local activities or project implementation, complaints and grievances shall first be filed with the appropriate elected official. If this is the case, grantees shall be required to notify the department of the complaint. A copy of the response shall also be submitted to the department. Every attempt must be made to respond to citizens within fifteen (15) days where practicable.

If a citizen feels the response from the local jurisdiction is unsatisfactory, he or she may appeal to the department for resolution. The department at that time may request additional information. Every effort will be made by the department to provide a full response within thirty (30) days.

If valid and sufficient data has been provided to substantiate the complaint, an investigation will be conducted. The extent of an investigation depends on the scope and depth of the issues involved.

If the complaint is more appropriately directed toward the CDBG program activities, the same procedure will be followed except all communications are between the state and the complainant.

This plan shall become effective January 23, 2018.



Chief Elected Official

**Notice of Public Hearing
on Proposed Grant
Activities**

The city of Shelley is submitting a proposal to the Idaho Department of Commerce for an Idaho Community Development Block Grant (CDBG) in the amount of \$150,000. The proposed project is to make improvements to the Shelley Senior Center.

The hearing will include a discussion of the application, scope of work, budget, schedule, benefits of the project, how CDBG funds will benefit low and moderate income persons, and location of the proposed project. The application, related documents, and ICDBG Application Handbook will be available for review.

The hearing has been scheduled for January 14th, 7:30 at the City Hall. Verbal and written comments will be accepted prior to and at the hearing.

The hearing will be held in a facility that is accessible to persons with disabilities. Special accommodations will be available, upon request, five (5) days prior to the hearing in a format that is usable to persons with disabilities. For more information, contact Sandy Gaydusek at 208-357-3390.

Stacy Pascoe
101 South Emerson Ave
Shelley, ID 83274

This Notice can be provided

In a format accessible to persons with disabilities and/or persons with limited English proficiency upon request.

Al ser solicitada, ésta notificación puede ser proveída en un formato fácil de usar para personas con discapacidad y/o personas con conocimientos limitados del Inglés.

**Publish: 1/3, 1/4/20
(2665)**

Legals

AFFIDAVIT OF PUBLICATION

County of Bingham)

SS

State of Idaho)

I, Judy Rea do solemnly swear that I am the Legal Coordinator of The Morning News, which is a daily newspaper of general circulation, published each day except Sunday at Blackfoot, Bingham County, Idaho, said newspaper having been so published at Blackfoot, aforesaid for more than one year past; that said newspaper heretofore complied with all the provisions of Chapter 154 of the Sessions Laws of Idaho of 1911, approved March 11, 1911, and duly designated, pursuant to law, a particular day of the week as the day on which legal notices required by law or by the order of any Court of competent jurisdiction within the State of Idaho shall be published to-wit: of each week; that the notice attached hereto and which is a part of this affidavit and part of the proof of publication was published in said issue of said newspaper 2 consecutive days the first publication having been made on the 3 day of January 2020, and the last publication having been made on the 4 day of January 2020; that said notice was published in the regular and entire issue of every number of the paper as aforesaid during the period and time of publication, and that notice was published, in the newspaper and not in a supplement.

Judy Rea

On this 5 day of February, in the year of 2020, before me a Notary Public of the State, personally appeared Judy Rea known or identified to me to be the person whose name is subscribed to the within instrument, and being by me the first duly sworn, declared that the statements therein are true, and acknowledged to me that the executed the same.

[Signature]

Notary Public for the State of Idaho
Residing at Blackfoot, Idaho
My Commission Expires:

9/03/25

Affidavit Processing Fee.....\$5.00

LAURIE A ALLEN
Notary Public - State of Idaho
Commission Number 20191799
My Commission Expires 09-03-2025



PUBLIC HEARING

SHELLEY SENIOR CENTER

JANUARY 14, 2020 | 7:30 P.M.

Phase II of the Shelley Senior Center remodel is an continuation of upgrades to make the facility safe and functional for area seniors.

COMMENTS:

PROJECT



- Structural improvements to the kitchen serving area
- Replace kitchen island and service counter with stainless steel.
- Drop ceiling in kitchen to cover exposed beams
- Addition of janitorial closet and mop sink
- Improved hand rail for each side of the basement staircase
- ADA upgrades to both bathrooms
- Additions to the bathroom for emergency shelter
- Handicap signage added to parking spots

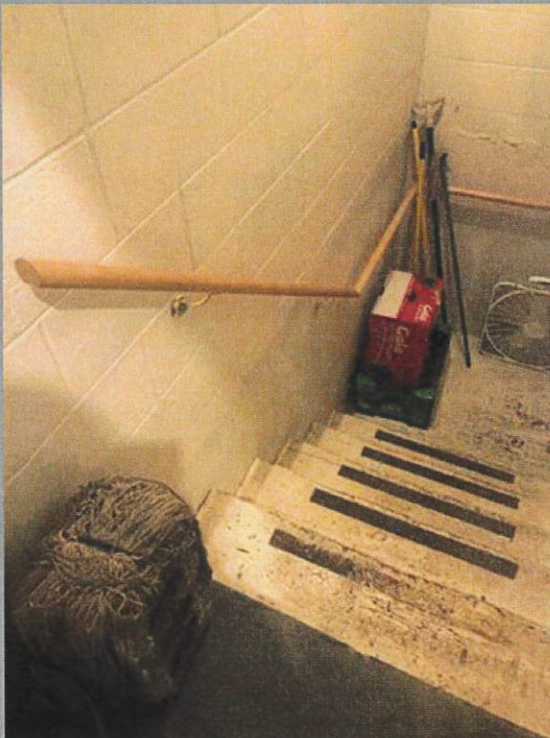

Budget

The majority of the Community Development Black Grant funding will be used for construction labor, supplies and equipment.

The Shelley Senior Center received additional matching funds from the CHC Foundation.

CITY OF SHELLEY
COUNCIL MEETING
MINUTES

January 14, 2020

PRESENT: Mayor: Stacy Pascoe
Council President: Earl Beattie
Councilpersons: Jeff Kelley, Kim Westergard and Adam French
Police Chief: Rod Mohler
P.W. Director: Justin Johnson
Rec Director: Mikal Anderson
City Clerk: Sandy Gaydusek, absent
Assist. City Clerk: Jasmine Marroquin
City Attorney: B.J. Driscoll

The Mayor called the meeting to order at 7:30p.m.

Justin Johnson led the Pledge of Allegiance and Kim Westergard gave the invocation.

Kim moved to accept the following items on the Consent Agenda:

- a. the minutes of December 10, 2019 Council Meeting
- b. November Expenditures
- c. November Overall Budget & Treasure's report
- d. December Expenditures
- e. December Overall Budget & Treasurer's report

Jeff seconded the motion. Earl -aye; Jeff -aye; Kim -aye; and Adam -aye. The consent agenda was approved unanimously

Mayor Pascoe thanked Jeff Kelley for his service as a council member, and honored him with a plaque.

The swearing in ceremony began with the Mayor Pascoe swearing in the newly elected official's Adam French and Leif Watson.

The public hearing for the Sr. Citizen Center proposed grant activities began with Amanda Collins 214 E. Center Pocatello, ID representing SICOG asking the City of Shelley to sponsor a grant for Phase II of their building improvements. She said in Phase I we did not complete all the renovations that we wanted to. We want to make an emergency shelter in the center for the seniors in case of disaster.

Kim asked "How much is the grant for?" Amanda replied "\$150,000"
Adam asked "How confident are you that you will complete the project?" Amanda replied
"We project we will complete the project in January 2021." We are also asking for the city to
make SICOG the certified grant administrator.

Hearing opened 7:43 p.m.
Those who are in favor can make comment: None
Those who are neutral can make comment: None
Those who are against can make comment: None
Hearing closed at 7:45pm

Kim motioned to approve that the city sponsor the grant for the Senior Citizen Center. Adam
Seconded. Unanimous – Aye
Kim motioned that we assign SICOG as the certified grant administrator. Adam Seconded.
Unanimous – Aye

Public Hearing to consider increase in water fees.
B.J presented that the city is proposing that an increase of water rates over 5% beginning
February 1, 2020. Water fees would go from \$21.03 to \$26.03 a month and meters would
increase by 23.77%. The increase is due to the additional costs of capital improvements.

BJ asked if there are any written statements? Jasmine notified that no written statements have
been received.

Hearing was opened at 7:47 p.m.
Those who are in favor can make comment: None
Those who are neutral can make comment:
Dan Watson 688 S. Park Ave Shelley, ID asked what is the money for?
Mayor explained it is for a new pressure system and infrastructure.
Mr. Watson said he is concerned that the line will not hold up and issues from the main line to
the homes, the lines are old. Will the city have enough funds to fix any issues that may come up?

Mayor explained that we are expecting issue but we do not know until it happens. That is why we
need to raise the rates a little so we don't have to raise them dramatically.

Those who are against can make comment: None

Hearing closed at 7:54 p.m.

EXHIBIT TWO: Procurement

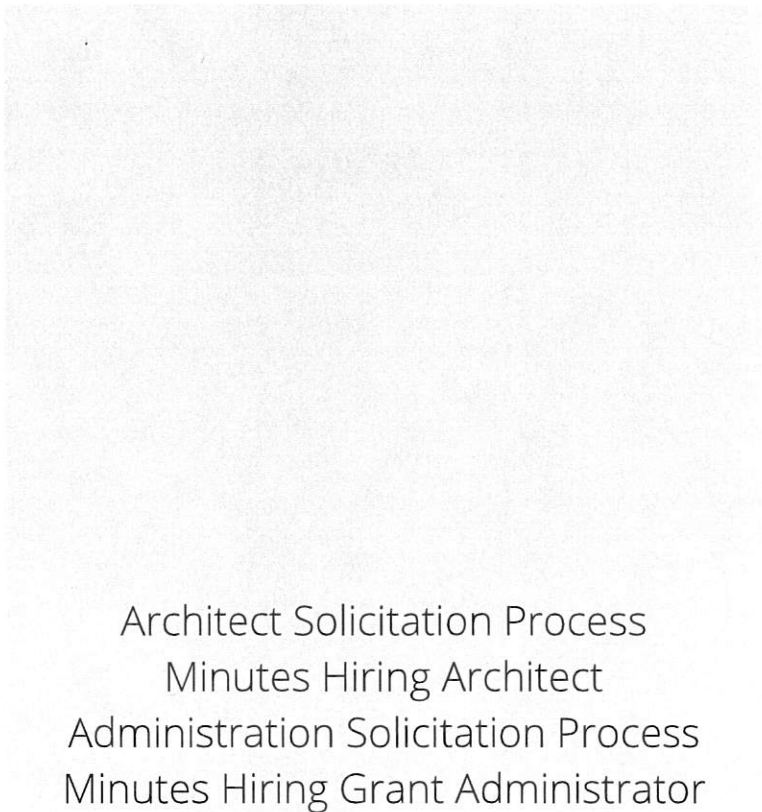

Architect Solicitation Process
Minutes Hiring Architect
Administration Solicitation Process
Minutes Hiring Grant Administrator

ARCHITECT PROCUREMENT

The architectural cost of this project is under \$25,000. The Micro Purchase Procedure was used to secure an architect for the project.

The architect, nbw architects, p.a., were part of the Phase One development of the Shelley Senior Center, and, because of their familiarity with the project, they were hired again by the Shelley Senior Center as part of Phase Two. It was a unanimous vote by the Shelley Senior Center Board of Directors on January 24th, 2020.

A copy of the minutes from that meeting are attached

MINUTES FOR BOARD MEETING HELD ON JANUARY 24th 2020

ATTENDING: Linda Beal, Jerry Byington, Ross Hainsworth, Ron Harada, Verle Kotter, Patricia Morris, Doris Nuttall, Barbara Steele, Judy Thomas & Denine Wong.

Minutes read by Linda Beal. A motion to accept minutes was made by Barbara Steele and a second by Patricia Morris. Then unanimously approved.

Manager's report given by Denine Wong. The Kiwanis club is doing the Annual Easter Egg Hunt again this year. They requested that we donate money for already filled eggs instead of buying and filling them ourselves. A motion was made by Linda Beal to donate \$40.00 for 250 eggs. A second by Barbara Steele. Then unanimously approved.

Amanda who is writing our grant for phase 2 said she had been to the public hearing and that the city is very supportive of our efforts. She also visited with The Emergency Manager for Bingham County who was also very supportive and like to approve the Center to be an Emergency Shelter, but the Center would need a shower and a generator.

A motion was made by Patricia Morris that we approve Nick Hansen from NBW Architect as our Architect for the grant phase 2. A second by Linda Beal and unanimously approved.

As a new Goal for the year: Seniors and Pets food project. This will help seniors that can't afford pet food. Jerry Byington suggested an adoption day where Seniors can see them and touch and maybe adopt them.

Looking towards a Pinnacle Jamboree in April. A clothing exchange in April also. Financial report reviewed: A motion was made to accept the Financial report by Judy Thomas and a second by Patricia Morris. Then unanimously approved.

A motion to adjourn was made by Patricia Morris, A second by Ross Hainsworth Then unanimously approved.

GRANT ADMINISTRATION PROCUREMENT

The Grant Administration cost of this project is under \$25,000. The Micro Purchase Procedure was used to secure an administrator to provide the administration services for the project.

The potential grantee selected SICOG as the administrator for this grant unanimously at their City Council Meeting on January 14th, 2020.

City council meeting minutes are attached.

CITY OF SHELLEY
COUNCIL MEETING
MINUTES

January 14, 2020

PRESENT: Mayor: Stacy Pascoe
Council President: Earl Beattie
Councilpersons: Jeff Kelley, Kim Westergard and Adam French
Police Chief: Rod Mohler
P.W. Director: Justin Johnson
Rec Director: Mikal Anderson
City Clerk: Sandy Gaydusek, absent
Assist. City Clerk: Jasmine Marroquin
City Attorney: B.J. Driscoll

The Mayor called the meeting to order at 7:30p.m.

Justin Johnson led the Pledge of Allegiance and Kim Westergard gave the invocation.

Kim moved to accept the following items on the Consent Agenda:

- a. the minutes of December 10, 2019 Council Meeting
- b. November Expenditures
- c. November Overall Budget & Treasure's report
- d. December Expenditures
- e. December Overall Budget & Treasurer's report

Jeff seconded the motion. Earl -aye; Jeff -aye; Kim -aye; and Adam -aye. The consent agenda was approved unanimously

Mayor Pascoe thanked Jeff Kelley for his service as a council member, and honored him with a plaque.

The swearing in ceremony began with the Mayor Pascoe swearing in the newly elected official's Adam French and Leif Watson.

The public hearing for the Sr. Citizen Center proposed grant activities began with Amanda Collins 214 E. Center Pocatello, ID representing SICOG asking the City of Shelley to sponsor a grant for Phase II of their building improvements. She said in Phase I we did not complete all the renovations that we wanted to. We want to make an emergency shelter in the center for the seniors in case of disaster.

Kim asked "How much is the grant for?" Amanda replied "\$150,000"

Adam asked "How confident are you that you will complete the project?" Amanda replied "We project we will complete the project in January 2021." We are also asking for the city to make SICOG the certified grant administrator.

Hearing opened 7:43 p.m.

Those who are in favor can make comment: None

Those who are neutral can make comment: None

Those who are against can make comment: None

Hearing closed at 7:45pm

Kim motioned to approve that the city sponsor the grant for the Senior Citizen Center. Adam Seconded. Unanimous – Aye

Kim motioned that we assign SICOG as the certified grant administrator. Adam Seconded. Unanimous – Aye

Public Hearing to consider increase in water fees.

B.J presented that the city is proposing that an increase of water rates over 5% beginning February 1, 2020. Water fees would go from \$21.03 to \$26.03 a month and meters would increase by 23.77%. The increase is due to the additional costs of capital improvements.

BJ asked if there are any written statements? Jasmine notified that no written statements have been received.

Hearing was opened at 7:47 p.m.

Those who are in favor can make comment: None

Those who are neutral can make comment:

Dan Watson 688 S. Park Ave Shelley, ID asked what is the money for?

Mayor explained it is for a new pressure system and infrastructure.

Mr. Watson said he is concerned that the line will not hold up and issues from the main line to the homes, the lines are old. Will the city have enough funds to fix any issues that may come up?

Mayor explained that we are expecting issue but we do not know until it happens. That is why we need to raise the rates a little so we don't have to raise them dramatically.

Those who are against can make comment: None

Hearing closed at 7:54 p.m.

EXHIBIT THREE: Fair Housing/ADA

Fair Housing Resolution
504/ADA Transition Plan
ADA Checklist Documentation

Fair Housing Resolution

LET IT BE KNOWN TO ALL PERSONS OF the City of Shelley that discrimination on the basis of race, color, religion, gender or national origin in the sale, rental, leasing or financing of housing or land to be used for construction of housing or in the provision of brokerage services is prohibited by Title VIII of the 1968 Civil Rights Act (Federal Fair Housing Law).

It is the policy of the City of Shelley to encourage equal opportunity in housing for all persons regardless of race, color, religion, gender or national origin. The Fair Housing Amendments Act of 1988 expands coverage to include disabled persons and families with children. Therefore, the city does hereby pass the following Resolution.

BE IT RESOLVED that within available resources the City will assist all persons who feel they have been discriminated against because of race, color, religion, gender, national origin, disability or familial status to seek equity under federal and state laws by referring them to the U.S. Department of Housing and Urban Development, Office of Fair Housing and Equal Opportunity, Compliance Division.

BE IT FURTHER RESOLVED that the City shall publicize this Resolution and through this publicity shall encourage owners of real estate, developers, and builders to become aware of their respective responsibilities and rights under the Federal Fair Housing Law and amendments and any applicable state or local laws or ordinances.

SAID PROGRAM will at a minimum include: 1) publicizing this resolution; 2) posting applicable fair housing information in prominent public areas; 3) providing fair housing information to the public; 4) preparing a fair housing assessment; and 5) declaring April as Fair Housing Month.

EFFECTIVE DATE

This Resolution shall take effect January 23, 2018.

Attest

Chief Elected Official

City of Shelley-Transition Plan

For 504/ADA Compliance

A committee meeting was conducted to review the City of Shelley facilities and policies and procedures for compliance issues with the 504/Americans with Disabilities Act in September of 2018.

Committee members are: Sandy Gaydusek, Stacy Pascoe

A review of the City owned facilities involved the following: **The following items are considered obstacles to reasonable accommodations for City owned facilities as well as impediments found in City program policies and procedures. Recommendations are being made by the Committee to plan and budget for the following improvements:**

Facility Location	Task	Target Date/ Estimated Cost
Pillsbury Park/Pool	Need to post appropriate Accessible Parking Sign at a minimum height of 5 feet.	August 2019 \$150.00
Pillsbury Park/Pool	Need to add van accessible parking spaces. One for every six accessible spaces. This should also be marked with a "Van Accessible" sign. Van accessible	August 2019 \$200.00
Pillsbury Park/Pool	Door handles are not lever or loop handles that can be easily grasped.	August 2019 \$50.00/each
Pillsbury Park/Pool	Proper signage is not posted on bathrooms. Signs should include raised tactile characters and Braille.	August 2019 \$60.00/each
Pillsbury Park/Pool	Restrooms are not accessible for those with disabilities. An accessible stall should be included in the facility. This stall should be a minimum (60in width for turn around space) and the entrance should be a minimum of 32 inches. Restrooms should also include grab bars. 42 inch minimum length bar on the side wall and 36 inch length on the back wall. Bars should be 33 to 36 inches from the ground.	September 2021 \$50,000.00
City Hall	The accessible parking space needs a 5 ft access aisle next to it.	October 2020 \$2,000.00
City Hall	Re-do ADA entrance ramp to meet slope requirements to access into building	October 2021 \$12,000.00

City Hall	Review and update restrooms to be ADA compliant	October 2020 \$
City Hall	The accessible parking sign needs to be raised to a minimum of 5 feet (measured from the ground to the bottom of the sign).	August 2019 \$50.00/each
City Hall	Every permanent room or space (such as restrooms, offices, or meeting rooms, etc) should have a sign with good contrast between characters and background, adequate character size for viewing distance, raised (tactile) characters and Braille.	August 2019 \$60.00/each
Brinkman Park	Accessible parking space should be located at the closest possible route to the park with an ADA access aisle and ADA Sign.	October 2021 \$1,000.00
Brinkman Park	Sidewalks and smooth pathways should be located on park grounds for accessible transportation from one area to another.	October 2021 \$7,500.00
City Park	Accessible parking should be added to the park (1 per every 25 spaces). Parking should be marked with appropriate signage and an access aisle.	October 2021 \$5,000.00/each
City Park	Sidewalks and smooth pathways should be added to the park to help provide accessible transportation from one area of the park to another.	October 2021 \$50,000.00
City Park	ADA restrooms could be added in the future to help accommodate those unable to use portable restrooms.	October 2021 \$50,000.00
James Bleak Memorial Park	ADA Parking should be added with proper signage and accessible curb.	November 2022 \$5,000.00
James Bleak Memorial Park	Sidewalks and smooth paths should be added to allow for accessible transportation through the park.	November 2022 \$7,500.00

Policy/Procedure	Task	Target Date
Providing training on 504/ADA, including access issues, sensitivity, and awareness on different disability groups.	The City should schedule yearly training on 504/ADA to help keep staff members up to date on policies.	December 2018

A designated coordinator for the 504/ADA compliance requirements	Assigned a coordinator for 504/ADA compliance requirements	December 2018
Staff completes training on the basics of the ADA by completing the Title II online Tutorial.	Staff should be given time at work to complete the Title II online Tutorial.	December 2018
Identify the individuals with disabilities and other individuals who helped in the self-evaluation and transition plan.	In the future individuals with disabilities should be invited to City owned locations to give their input on the City's buildings and policies.	June 2019
Staff knows how to alert people with disabilities of an emergency in the area and how to assist them in leaving the building or how to access shelters that are accessible.	All current and new city employees should receive training on how to help people with disabilities in the case of an emergency.	March 2019
Reviewing the DOJ's 2010 regulations on ADA.	City staff should review the DOJ's 2010 regulations on the ADA.	December 2018
Making efforts to include people with disabilities on your advisory boards and committees.	The City should look to seek out individuals with disabilities they think are qualified to be on advisory boards and committees.	June 2019
Providing assistive listening devices.	The City should obtain listening devices to help those individuals who are hard of hearing.	October 2019
Material provided in large print or electronically and signs accessible to people who are blind or have low vision.	Signs should be accessible to those who are blind or have low vision. Materials should be provided in large print or electronically to help individuals with disabilities.	June 2020

Reviewed and recommended by 504/ADA Designated Employee _____

Dated: _____



ADA Checklist for Existing Facilities

Based on the 2010 ADA Standards for Accessible Design



Produced by
Institute for Human Centered Design
www.HumanCenteredDesign.org

www.ADAchecklist.org
2014



ADA National Network
www.ADAa.org

Questions on the ADA 800-949-4232 voice/tty
Questions on checklist 617-695-0085 voice/tty
ADAinfo@NewEnglandADA.org

This checklist was produced by the New England ADA Center, a project of the Institute for Human Centered Design and a member of the ADA National Network. This checklist was developed under a grant from the Department of Education, NIDRR grant number H133A060092-09A. However the contents do not necessarily represent the policy of the Department of Education, and you should not assume endorsement by the Federal Government.

Questions or comments on the checklist contact the New England ADA Center at 617-695-0085 voice/tty or
ADAinfo@NewEnglandADA.org

For the full set of checklists, including the checklists for recreation facilities visit www.ADAchecklist.org.

Institute for Human Centered Design
2011

www.ADAchecklist.org

ADA Checklist for Existing Facilities

The Americans with Disabilities Act (ADA) requires state and local governments, businesses and non-profit organizations to provide goods, services and programs to people with disabilities on an equal basis with the rest of the public.

Some people think that only new construction and alterations need to be accessible and that older facilities are "grandfathered," but that's not true. Because the ADA is a civil rights law and not a building code, older facilities are often required to be accessible to ensure that people with disabilities have an equal opportunity to participate.

The ADA has different requirements for state and local governments and for places of public accommodation (businesses and non-profit organizations that serve the public).

Requirements for State and Local Governments

State and local governments must ensure that services, programs and activities, when viewed in their entirety, are accessible to people with disabilities. This is part of public entities' program accessibility obligations. Alterations to older buildings may be needed to ensure program accessibility. Generally this is a greater obligation than "readily achievable barrier removal" the standard that applies to public accommodations. State and local governments are not required to take any action that would result in undue financial and administrative burdens.

State and local governments' ADA obligations for program accessibility are in the Department of Justice's ADA Title II regulations 28 CFR Part 35.150.

How to Use this Checklist

Get Organized

One person can conduct a survey, but it's easier with two people. One person can take measurements and the other person can fill out the checklist and take photos.

Obtain Floor Plan or Make Sketch

A floor plan helps the surveyors get organized and to know how many elements there are, such as entrances and toilet rooms. If plans are not available, sketch the exterior and interior layout of interior and exterior spaces and mark the elements on the sketch.

Make Copies of the Checklist

Determine how many copies of each section of the checklist you need. For example, most facilities have more than one toilet room.

Gather Tools

- Checklist
- Clipboard
- Tape measure
- Electronic or carpenter's level - 24 inches
- Door pressure gauge or fish scale
- Camera
- Bag to hold these items

Requirements for Places of Public Accommodation

Businesses and non-profit organizations that serve the public must remove architectural barriers when it is "readily achievable" to do so; in other words, when barrier removal is "easily accomplishable and able to be carried out without much difficulty or expense."

The decision of what is readily achievable is made considering the size, type, and overall finances of the public accommodation and the nature and cost of the access improvements needed. Barrier removal that is difficult now may be readily achievable in the future as finances change.

Public accommodations' ADA obligations for barrier removal are in the Department of Justice's ADA Title III regulations 28 CFR Part 36.304.

Priorities for Accessibility

The checklist follows the four priorities that are listed in the Department of Justice ADA Title III regulations. These priorities are equally applicable to state and local government facilities.

Priority 1 - Accessible approach and entrance

Priority 2 - Access to goods and services

Priority 3 - Access to public toilet rooms

Priority 4 - Access to other items such as water fountains and public telephones

Conduct the Survey

Start Outside

Start from site arrival points such as drop-off areas and sidewalks. Determine if there is an accessible route to an accessible entrance. If there is a parking lot or garage check for the correct number of accessible parking spaces, including van-accessible spaces. Is there an accessible route from the accessible parking spaces to an accessible entrance? Next survey the entrances. If there is an accessible entrance, determine if there are signs at inaccessible entrances directing people to the accessible entrance. Go inside and continue through the facility.

Keep Good Notes

Write on the front of each checklist where you are surveying. You may end up with six toilet room checklists. When you get back to your office you'll want to know which one is the checklist for the first floor women's room. If there isn't an accessible entrance you'll want to indicate how many steps there are and how much space is available to install a ramp or lift. This is a good time to take photographs.

Take Good Measurements

When in doubt write it down. It's better to have too much information than not enough. Even if something is in compliance it's helpful to have exact measurements.

2010 ADA Standards for Accessible Design

The checklist is based on the 2010 ADA Standards for Accessible Design (2010 Standards). The checklist does not include all sections of the 2010 Standards. For example there are no questions about patient rooms in hospitals or guest rooms in hotels. Consult the 2010 Standards for situations not covered in the checklist. Full compliance with the 2010 Standards is required only for new construction and alterations.

Safe Harbor – Construction Prior to March 15, 2012

Elements in facilities built or altered before March 15, 2012 that comply with the 1991 ADA Standards for Accessible Design (1991 Standards) are not required to be modified to specifications in the 2010 Standards. For example, the 1991 Standards allow 54 inches maximum for a side reach range to a control such as the operating part of a paper towel dispenser. The 2010 Standards lower that side reach range to 48 inches maximum. If a paper towel dispenser was installed prior to March 15, 2012 with the highest operating part at 54 inches, the paper towel dispenser does not need to be lowered to 48 inches.

Elements in the 2010 Standards that aren't in the 1991 Standards

The 2010 Standards contain elements that are not in the 1991 Standards. These elements include recreation facilities such as swimming pools, team and player seating, accessible routes to court sports facilities, saunas and steam rooms, fishing piers, play areas, exercise machines, golf facilities, miniature golf facilities, amusement rides, shooting facilities with firing positions, and recreational boating facilities. Because these elements are not in the 1991 Standards, they are not subject to the safe harbor exemption. State and local governments must make these items



Parking Spaces
Measure from the inside edge of the painted line to the inside of the opposite painted line or edge of space.



Door Clear Width
Open the door 90 degrees, measure from the face of the door to the edge of the door stop.



Door Opening Force
If you're using a door pressure gauge place it where you would push open the door.



If you're using a fish scale place it where you would pull open the door.

accessible if necessary to ensure program accessibility, unless an undue burden would result. Public accommodations must remove architectural barriers to these items.

What this Checklist is Not

The ADA Title II and III regulations require more than program accessibility and barrier removal. The regulations include requirements for nondiscriminatory policies and practices and for the provision of auxiliary aids and services, such as sign language interpreters for people who are deaf and material in Braille for people who are blind. This checklist does not cover those requirements.

Since this checklist does not include all of the 2010 Standards it is not intended to determine compliance for new construction or facilities being altered.

What are Public Accommodations?

Under the ADA public accommodations are private entities that own, lease, or operate a place of public accommodation. This means that both a landlord who leases space in a building to a tenant and the tenant who operates a place of public accommodation have responsibilities to remove barriers.

A place of public accommodation is a facility whose operations affect commerce and fall within at least one of the following 12 categories:

- 1) Places of lodging (e.g., inns, hotels, motels, except for owner-occupied establishments renting fewer than six rooms)
- 2) Establishments serving food or drink (e.g., restaurants and bars)
- 3) Places of exhibition or entertainment (e.g., motion picture houses, theaters, concert



Accessible Slopes
You can measure slope with a 24 inch level and a tape measure. Put the level on the surface in the direction you are

measuring. Put one end at the high point of the surface and raise the other end so that the bubble is in the middle of the level's gauge. The level is now level. Measure the distance between the end of the level at its bottom point and the surface.

For a ramp the maximum running slope allowed is 1:12. That means for every inch of height change there should be at least 12 inches of ramp run. If the distance between the bottom of the level and the ramp surface is 2 inches or less, then the slope is 1:12 or less (2:24 = 1:12 and 1.5:24 = 1:16 which is a more gradual slope than 1:12). If the distance is greater than 2 inches, the ramp is too steep. For example, if the distance is 3 inches, then the slope is 1:8 (3:24 = 1:8 which is a steeper slope than 1:12).

For the parts of an accessible route that aren't a ramp, the maximum running slope allowed is 1:20. That means for every inch of height change there must be at least 20 inches of route run. The distance from the bottom edge of the level to the surface should be no more than 1.2 inches (1.2:24 = 1:20).

halls, stadiums)

- 4) Places of public gathering (e.g., auditoriums, convention centers, lecture halls)
- 5) Sales or rental establishments (e.g., bakeries, grocery stores, hardware stores, shopping centers)
- 6) Service establishments (e.g., laundromats, dry-cleaners, banks, barber shops, beauty shops, travel services, shoe repair services, funeral parlors, gas stations, offices of accountants or lawyers, pharmacies, insurance offices, professional offices of health care providers, hospitals)
- 7) Public transportation terminals, depots, or stations (not including facilities relating to air transportation)
- 8) Places of public display or collection (e.g., museums, libraries, galleries)
- 9) Places of recreation (e.g., parks, zoos, amusement parks)
- 10) Places of education (e.g., nursery schools, elementary, secondary, undergraduate, or postgraduate private schools)
- 11) Social service center establishments (e.g., day care centers, senior citizen centers, homeless shelters, food banks, adoption agencies)
- 12) Places of exercise or recreation (e.g., gymnasiums, health spas, bowling alleys, golf courses).

For the cross slope of an accessible route the maximum slope allowed is 1:48. The distance from the bottom edge of the level to the surface should be no more than ½ inch (.5:24 = 1:48). The cross slope of an accessible route is the slope that is perpendicular to the direction of pedestrian travel.

Slopes may also be measured using a digital level. Be sure to read the instructions. Measure with the percent calculation rather than the degrees calculation. For a ramp the maximum running slope allowed is 8.33% (8.33% is a 1:12 slope). For an accessible route without a ramp the maximum running slope allowed is 5% (1:20). For the cross slope of an accessible route the maximum slope allowed is 2.083% (1:48).

Check that You Got Everything - Before you leave the site review all the checklists. Make sure you know which checklist goes with which entrance and which toilet room and that you've got all the information you need. It is better to do it now than to have to go back.

After the Survey

List Barriers and Solutions - Consider the solutions listed beside each question on the checklist and add your own ideas. Consult with building contractors and equipment suppliers to estimate the costs for making modifications.

Resources

U.S. Department of Justice ADA Information
800-514-0301 voice
800-514-0383 TTY
www.ada.gov

ADA National Network
800-949-4232 voice/TTY connects to your regional ADA Center
www.adanet.org

U.S. Access Board
800-872-2253 voice
800-993-2822 TTY
www.access-board.gov

ADA Title III Regulations 28 CFR Part 36
www.ada.gov/regs2010/titleIII_2010_regulations.htm

2010 ADA Standards for Accessible Design
www.ada.gov/2010ADAstandards_index.htm

1991 ADA Standards for Accessible Design
www.ada.gov/stdspdf.htm

Tax Deductions and Credits for Barrier Removal
www.ada.gov/taxincnt.htm

Acknowledgements

Many of the illustrations are from the U.S. Department of Justice and the U.S. Access Board or are based on illustrations produced by the U.S. Access Board and the U.S. Department of Justice.

Develop an Implementation Plan

Although an implementation plan is not required, the Department of Justice recommends such a plan, specifying what barriers will be removed and when solutions will occur: "Such a plan...could serve as evidence of a good faith effort to comply." Prioritize items, make a timeline and develop a budget. Where the removal of barriers is not readily achievable, consider whether there are alternative methods for providing access that are readily achievable such as curbside takeout service at a restaurant with an accessible intercom system outside.

Make Changes - Use the 2010 ADA Standards for Accessible Design. Note: Until March 15, 2012 the 1991 ADA Standards for Accessible Design may be used for readily achievable barrier removal. Check whether local and state building codes require greater accessibility when alterations are undertaken.

Follow Up - Review the implementation plan each year to evaluate whether more access improvements have become readily achievable.

ADA Checklist for Existing Facilities

Priority 1 – Approach & Entrance

Based on the 2010 ADA Standards for Accessible Design



Project Shelly Senior Center

Building _____

Location Shelley Idaho _____

Date 1/23/18 _____

Surveyors Susan Lorenz _____

Contact Information 208-233-4535 _____

ext 1 _____

An accessible route from site arrival points and an accessible entrance should be provided for everyone.



This checklist was produced by the New England ADA Center, a project of the Institute for Human Centered Design and a member of the ADA National Network. This checklist was developed under a grant from the Department of Education, NIDRR grant number H133A060092-09A. However the contents do not necessarily represent the policy of the Department of Education, and you should not assume endorsement by the Federal Government.



Questions or comments on the checklist contact the New England ADA Center at 617-695-0085 voice/tty or ADAInfo@NewEnglandADA.org

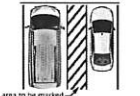

For the full set of checklists, including the checklists for recreation facilities visit www.ADAchecklist.org.

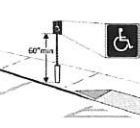
Priority 1 – Approach & Entrance	Comments	Possible Solutions													
<p>1.1 Is there at least one route from site arrival points (parking, passenger loading zones, public sidewalks and public transportation stops) that does not require the use of stairs? [See 2010 ADA Standards for Accessible Design – 206.2.1]</p> <p><input checked="" type="checkbox"/> Yes <input type="checkbox"/> No</p> <p>if yes, location of route: _____</p> <p>Photo #: _____</p>	<ul style="list-style-type: none"> Add a ramp Regrade to 1:20 maximum slope Add a lift if site constraints prevent other solutions 														
<p>Parking Accessible parking spaces should be identified by size, access aisle and signage.</p> <p>1.2 If parking is provided for the public, are an adequate number of accessible spaces provided? [208.2]</p> <p><input checked="" type="checkbox"/> Yes <input type="checkbox"/> No</p> <table border="1"> <tr> <td>Total #:</td> <td>15</td> </tr> <tr> <td>Accessible #:</td> <td>4</td> </tr> </table> <table border="1"> <thead> <tr> <th>Total Spaces</th> <th>Accessible Spaces</th> </tr> </thead> <tbody> <tr> <td>1 - 25</td> <td>1</td> </tr> <tr> <td>26 - 50</td> <td>2</td> </tr> <tr> <td>51 - 75</td> <td>3</td> </tr> <tr> <td>76 - 100</td> <td>4</td> </tr> </tbody> </table> <p>100+ see 2010 Standards 208.2</p> <p>Photo #: _____</p>	Total #:	15	Accessible #:	4	Total Spaces	Accessible Spaces	1 - 25	1	26 - 50	2	51 - 75	3	76 - 100	4	<ul style="list-style-type: none"> Reconfigure by repainting lines
Total #:	15														
Accessible #:	4														
Total Spaces	Accessible Spaces														
1 - 25	1														
26 - 50	2														
51 - 75	3														
76 - 100	4														
<p>1.3 Of the accessible spaces, is at least one a van accessible space? [208.2.4]</p> <p><input checked="" type="checkbox"/> Yes <input type="checkbox"/> No</p> <p>*For every 6 or fraction of 6 parking spaces required by the table above, at least 1 should be a van accessible space.</p> <p>2 spaces allow a van space to unload with a side door.</p> <p>Photo #: 1.2</p>	<ul style="list-style-type: none"> If constructed before 3/15/2012, parking is compliant if at least 1 in every 8 accessible spaces is van accessible Reconfigure by repainting lines 														

<p>1.4 Are accessible spaces at least 8 feet wide with an access aisle at least 5 feet wide? [502.2, 502.3]</p> <p><input checked="" type="checkbox"/> Yes <input type="checkbox"/> No</p> <p>Measurement: _____</p> <p>Note: Two spaces may share an access aisle. Check state/local requirements; some specify that each space have its own aisle.</p> <p>Photo #: _____</p>		<ul style="list-style-type: none"> Reconfigure by repainting lines
<p>1.5 Is the van accessible space:</p> <p>At least 11 feet wide with an access aisle at least 5 feet wide?</p> <p>Or</p> <p>At least 8 feet wide with an access aisle at least 8 feet wide? [502.3]</p> <p><input checked="" type="checkbox"/> Yes <input type="checkbox"/> No</p> <p>Measurement: _____</p> <p>Photo #: _____</p>		<ul style="list-style-type: none"> Reconfigure to provide van accessible space(s)
<p>1.6 Is at least 98 inches of vertical clearance provided for the van accessible space? [502.5]</p> <p><input checked="" type="checkbox"/> Yes <input type="checkbox"/> No</p> <p>Measurement: _____</p> <p>Photo #: _____</p>		<ul style="list-style-type: none"> Reconfigure to provide van accessible space(s)

<p>1.7 Are the access aisles marked so as to discourage parking in them? [502.3.3]</p> <p>Note: The marking method and color may be addressed by state/local requirements.</p>	<p><input checked="" type="checkbox"/> Yes <input type="checkbox"/> No</p>	 <p>area to be marked</p>	<p>Photo #:</p> <ul style="list-style-type: none"> • Mark access aisles
<p>1.8 Is the slope of the accessible parking spaces and access aisles no steeper than 1:48 in all directions? [502.4]</p>	<p><input checked="" type="checkbox"/> Yes <input type="checkbox"/> No</p> <p>Measurement:</p>		<p>Photo #:</p> <ul style="list-style-type: none"> • Regrade surface
<p>1.9 Do the access aisles adjoin an accessible route? [502.3]</p>	<p><input type="checkbox"/> Yes <input checked="" type="checkbox"/> No</p>		<p>They do have access aisles with the van accessible spaces. The other accessible spaces require walking to the nearby sidewalk cutout.</p> <p>Photo #:</p> <ul style="list-style-type: none"> • Create accessible route • Relocate accessible space
<p>1.10 Are accessible spaces identified with a sign that includes the International Symbol of Accessibility?</p> <p>Is the bottom of the sign at least 60 inches above the ground? [502.6]</p> <p>Note: The International Symbol of Accessibility is not required</p>	<p><input type="checkbox"/> Yes <input checked="" type="checkbox"/> No</p> <p><input type="checkbox"/> Yes <input checked="" type="checkbox"/> No</p> <p>Measurement:</p>		<p>The spaces are painted but no signs are installed.</p> <p>Photo #:</p> <ul style="list-style-type: none"> • Install signs

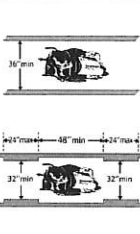
<p>on the ground.</p>			<p>Photo #:</p>
<p>1.11 Are there signs reading "van accessible" at van accessible spaces? [502.6]</p>	<p><input type="checkbox"/> Yes <input checked="" type="checkbox"/> No</p>		<p>Photo #:</p> <ul style="list-style-type: none"> • Install signs
<p>1.12 Of the total parking spaces, are the accessible spaces located on the closest accessible route to the accessible entrance(s)? [208.3.1]</p> <p>Note: If parking serves multiple entrances, accessible parking should be dispersed.</p>	<p><input checked="" type="checkbox"/> Yes <input type="checkbox"/> No</p>		<p>Photo #:</p> <ul style="list-style-type: none"> • Reconfigure spaces
<p>Exterior Accessible Route</p>			
<p>1.13 Is the route stable, firm and slip-resistant? [302.1]</p>	<p><input checked="" type="checkbox"/> Yes <input type="checkbox"/> No</p>		<p>Photo #:</p> <ul style="list-style-type: none"> • Repair uneven paving • Fill small bumps and breaks with patches • Replace gravel with asphalt or other surface

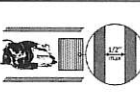
<p>1.14 Is the route at least 36 inches wide? [403.5.1]</p> <p>Note: The accessible route can narrow to 32 inches min. for a max. of 24 inches. These narrower portions of the route must be at least 48 inches from each other.</p>	<p><input checked="" type="checkbox"/> Yes <input type="checkbox"/> No</p> <p>Measurement:</p>		<p>Photo #:</p> <ul style="list-style-type: none"> • Change or move landscaping, furnishings or other items • Widen route
<p>1.15 If the route is greater than 200 feet in length and less than 60 inches wide, is there a passing space no less than 60 x 60 inches? [403.5.3]</p>	<p><input type="checkbox"/> Yes <input type="checkbox"/> No</p> <p>Measurement:</p>		<p>NA</p> <p>Photo #:</p> <ul style="list-style-type: none"> • Widen route for passing space
<p>1.16 If there are grates or openings on the route, are the openings no larger than 1/2 inches?</p> <p>Is the long dimension perpendicular to the dominant direction of travel? [302.3]</p>	<p><input type="checkbox"/> Yes <input type="checkbox"/> No</p> <p>Measurement:</p> <p><input type="checkbox"/> Yes <input type="checkbox"/> No</p>		<p>NA</p> <p>Photo #:</p> <ul style="list-style-type: none"> • Replace or move grate

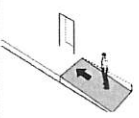
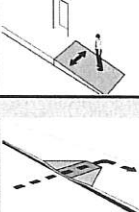

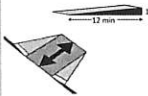
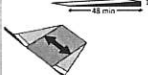
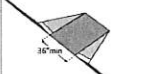
<p>1.17 Is the running slope no steeper than 1:20, i.e. for every inch of height change there are at least 20 inches of route run? [403.3]</p> <p>Note: If the running slope is steeper than 1:20, treat as a ramp and add features such as edge protection and handrail.</p>	<p><input checked="" type="checkbox"/> Yes <input type="checkbox"/> No</p> <p>Measurement:</p>		<p>Photo #:</p> <ul style="list-style-type: none"> • Regrade to 1:20 max.
<p>1.18 Is the cross slope no steeper than 1:48? [403.3]</p>	<p><input type="checkbox"/> Yes <input type="checkbox"/> No</p> <p>Measurement:</p>		<p>NA</p> <p>Photo #:</p> <ul style="list-style-type: none"> • Regrade to 1:48 max.
<p>Curb Ramps</p>			
<p>1.19 If the accessible route crosses a curb, is there a curb ramp? [402.2]</p>	<p><input type="checkbox"/> Yes <input checked="" type="checkbox"/> No</p>		<p>Photo #:</p> <ul style="list-style-type: none"> • Install curb ramp

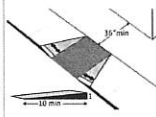
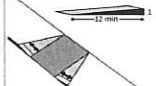
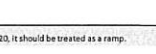
<p>1.20 Is the running slope of the curb ramp no steeper than 1:12, i.e. for every inch of height change there are at least 12 inches of curb ramp run? [406.1, 405.2]</p> <p><input type="checkbox"/> Yes <input checked="" type="checkbox"/> No</p> <p>Measurement: 1:19 (4 to 76)</p>		<p>The sidewalk cut is a little too steep. 1 to 19 (4 to 76) building inspector says the city will correct this when the street and sidewalk is repaced/repared</p> <p>Photo #:</p>	<ul style="list-style-type: none"> • Regrade curb ramp
<p>1.21 Is the cross slope of the curb ramp, excluding flares, no steeper than 1:48? [406.1, 405.3]</p> <p><input type="checkbox"/> Yes <input checked="" type="checkbox"/> No</p> <p>Measurement:</p>		<p>Photo #:</p>	<ul style="list-style-type: none"> • Regrade curb ramp
<p>1.22 Is the curb ramp, excluding flares, at least 36 inches wide? [406.1, 405.5]</p> <p><input checked="" type="checkbox"/> Yes <input type="checkbox"/> No</p> <p>Measurement:</p>		<p>Photo #:</p>	<ul style="list-style-type: none"> • Widen curb ramp

<p>1.23 At the top of the curb ramp is there a level landing [slope no steeper than 1:48 in all directions] that is at least 36 inches long and at least as wide as the curb ramp? [406.4]</p> <p><input checked="" type="checkbox"/> Yes <input type="checkbox"/> No</p> <p>Measurement:</p>		<p>Photo #:</p>	<ul style="list-style-type: none"> • Reconfigure • Add ramp flares
<p>If there are curb ramp flares, are the slopes of the flares no steeper than 1:30, i.e. for every inch of height change there are at least 10 inches of flare run? [406.3]</p> <p><input type="checkbox"/> Yes <input type="checkbox"/> No</p> <p>Measurement:</p>		<p>Photo #:</p>	<ul style="list-style-type: none"> • Add ramp flares • Regrade flares
<p>1.24 If the landing at the top is less than 36 inches long, are there curb ramp flares?</p> <p><input type="checkbox"/> Yes <input type="checkbox"/> No</p> <p>Are the slopes of the flares no greater than 1:12, i.e. for every inch of height change there are at least 12 inches of flare run? [406.4]</p> <p><input type="checkbox"/> Yes <input type="checkbox"/> No</p> <p>Measurement:</p>		<p>Photo #:</p>	<ul style="list-style-type: none"> • Add ramp flares • Regrade flares

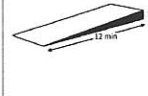

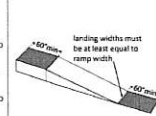
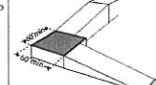
Ramps if any portion of the accessible route is steeper than 1:20, it should be treated as a ramp.

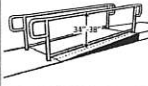
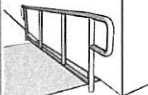
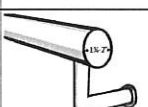
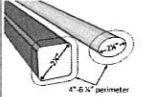

<p>1.25 If there is a ramp is it at least 36 inches wide? [405.5]</p> <p><input type="checkbox"/> Yes <input type="checkbox"/> No</p> <p>Measurement:</p> <p>Note: If there are handrails, measure between the handrails.</p>		<p>NA there is no ramp</p> <p>Photo #:</p>	<ul style="list-style-type: none"> • Alter ramp
<p>1.26 Is the surface stable, firm and slip resistant? [405.4]</p> <p><input type="checkbox"/> Yes <input type="checkbox"/> No</p> <p>Measurement:</p>	<p>NA</p>	<p>Photo #:</p>	<ul style="list-style-type: none"> • Resurface ramp
<p>1.27 For each section of the ramp, is the running slope no greater than 1:12, i.e. for every inch of height change there are at least 12 inches of ramp run? [405.2]</p> <p><input type="checkbox"/> Yes <input type="checkbox"/> No</p> <p>Measurement:</p> <p>Note: Rises no greater than 3 inches with a slope no steeper than 1:8 and rises no greater than 6 inches with a slope no steeper than 1:10 are permitted when such slopes are necessary due to space limitations.</p>		<p>Photo #:</p>	<ul style="list-style-type: none"> • Relocate ramp • Lengthen ramp to decrease slope

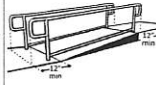
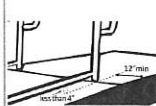

<p>1.28 Is there a level landing that is at least 60 inches long and at least as wide as the ramp?</p> <p><input type="checkbox"/> Yes <input type="checkbox"/> No</p> <p>At the top of the ramp? <input type="checkbox"/> Yes <input type="checkbox"/> No</p> <p>Measurement:</p> <p>At the bottom of the ramp? [405.7.2, 405.7.3] <input type="checkbox"/> Yes <input type="checkbox"/> No</p> <p>Measurement:</p>		<p>na</p> <p>Photo #:</p>	<ul style="list-style-type: none"> • Alter ramp • Relocate ramp
<p>1.29 Is there a level landing where the ramp changes direction that is at least 60 x 60 inches? [405.7.4]</p> <p><input type="checkbox"/> Yes <input type="checkbox"/> No</p> <p>Measurement:</p>		<p>na</p> <p>Photo #:</p>	<ul style="list-style-type: none"> • Alter ramp • Increase landing size
<p>1.30 If the ramp has a rise higher than 6 inches, are there handrails on both sides? [405.8]</p> <p><input type="checkbox"/> Yes <input type="checkbox"/> No</p> <p>Measurement:</p> <p>Note: Curb ramps are not required to have handrails.</p>		<p>na</p> <p>Photo #:</p>	<ul style="list-style-type: none"> • Add handrails

1.31	Is the top of the handrail gripping surface no less than 34 inches and no greater than 38 inches above the ramp surface? [505.4]	<input type="checkbox"/> Yes <input type="checkbox"/> No Measurement:		na Photo #:	<ul style="list-style-type: none"> Reconfigure or replace handrails Adjust handrail height
1.32	Is the handrail gripping surface continuous and not obstructed along the top or sides? [505.3] If there are obstructions, is the bottom of the gripping surface obstructed no greater than 20%? [505.6]	<input type="checkbox"/> Yes <input type="checkbox"/> No Measurement:		na Photo #:	<ul style="list-style-type: none"> Reconfigure or replace handrails
1.33	If the handrail gripping surface is circular, is it no less than 1 1/2 inches and no greater than 2 inches in diameter? [505.7.1]	<input type="checkbox"/> Yes <input type="checkbox"/> No Measurement:		na Photo #:	<ul style="list-style-type: none"> Replace handrails
1.34	If the handrail gripping surface is non-circular: Is the perimeter no less than 4 inches and no greater than 6 1/2 inches? [505.7.2]	<input type="checkbox"/> Yes <input type="checkbox"/> No Measurement:		na Photo #:	<ul style="list-style-type: none"> Replace handrails

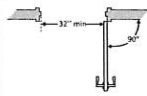
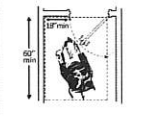

	Is the cross section no greater than 2 1/2 inches? [505.7.2]	<input type="checkbox"/> Yes <input type="checkbox"/> No Measurement:		na Photo #:	
1.35	Does the handrail: Extend at least 12 inches horizontally beyond the top and bottom of the ramp? Return to a wall, guard, or landing surface? [505.10.1] Note: If a 12 inch extension would be a hazard (in circulation path) it is not required.	<input type="checkbox"/> Yes <input type="checkbox"/> No Measurement:		na Photo #:	<ul style="list-style-type: none"> Alter handrails
1.36	To prevent wheelchair casters and crutch tips from falling off: Does the surface of the ramp extend at least 12 inches beyond the inside face of the handrail? Or Is there a curb or barrier that prevents the passage of a 4-inch diameter sphere? [405.9.1, 405.9.2]	<input type="checkbox"/> Yes <input type="checkbox"/> No Measurement:		na Photo #:	<ul style="list-style-type: none"> Add curb Add barrier Extend ramp width

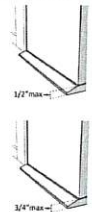
Entrance					
1.37	Is the main entrance accessible?	<input checked="" type="checkbox"/> Yes <input type="checkbox"/> No		na Photo #:	<ul style="list-style-type: none"> Redesign to make it accessible
1.38	If the main entrance is not accessible, is there an alternative accessible entrance? Can the alternative accessible entrance be used independently and during the same hours as the main entrance?	<input type="checkbox"/> Yes <input type="checkbox"/> No <input type="checkbox"/> Yes <input type="checkbox"/> No		na Photo #:	<ul style="list-style-type: none"> Designate an entrance and make it accessible Ensure that accessible entrance can be used independently and during the same hours as the main entrance
1.39	Do all inaccessible entrances have signs indicating the location of the nearest accessible entrance? [216.6]	<input type="checkbox"/> Yes <input type="checkbox"/> No		na Photo #:	<ul style="list-style-type: none"> Install signs Install signs on route before people get to inaccessible entrances so that people do not have to turn around and retrace route
1.40	If not all entrances are accessible, is there a sign at the accessible entrance with the International Symbol of Accessibility? [216.6]	<input type="checkbox"/> Yes <input type="checkbox"/> No		na Photo #:	<ul style="list-style-type: none"> Install sign

1.41	Is the clear opening width of the accessible entrance door at least 32 inches, between the face of the door and the stop, when the door is open 90 degrees? [404.2.3]	<input checked="" type="checkbox"/> Yes <input type="checkbox"/> No Measurement: 35		na Photo #:	<ul style="list-style-type: none"> Alter door Install offset hinges
1.42	If there is a front approach to the pull side of the door, is there at least 18 inches of maneuvering clearance beyond the latch side plus at least 60 inches clear depth? Note: See 2010 Standards 404.2.4 for maneuvering clearance requirements on the push side of the door and side approaches to the pull side of the door. On both sides of the door, is the ground or floor surface of the maneuvering clearance level (no steeper than 1:48)? [404.2.4]	<input checked="" type="checkbox"/> Yes <input type="checkbox"/> No Measurement: 32 inches and 9 feet		na Photo #:	<ul style="list-style-type: none"> Remove obstructions Reconfigure walls Add automatic door opener
1.43	If the threshold is vertical is it no more than 1/4 inch high? Or No more than 1/2 inch high with the top 1/4 inch beveled no steeper than 1:2, if the threshold was installed on or	<input type="checkbox"/> Yes <input type="checkbox"/> No Measurement: <input type="checkbox"/> Yes <input checked="" type="checkbox"/> No Measurement:		na Photo #:	<ul style="list-style-type: none"> Remove or replace threshold

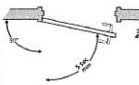
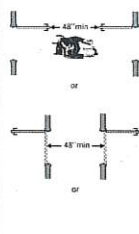
<p>after the 1991 ADA Standards went into effect (1/26/93)?</p> <p>Or</p> <p>No more than 1/4 inch high with the top 1/8 inch beveled no steeper than 1:2, if the threshold was installed before the 1991 ADA Standards went into effect (1/26/93)? [404.2.5, 303.2]</p> <p>Note: The first 1/8 inch of the 1/4 or 1/2 inch threshold may be vertical; the rest must be beveled.</p>	<p>Measurement: <input type="checkbox"/> Yes <input checked="" type="checkbox"/> No</p>		<p>Photo #:</p>
<p>1.44 Is the door equipped with hardware that is operable with one hand and does not require tight grasping, pinching or twisting of the wrist?</p> <p>Door handle? <input type="checkbox"/> Yes <input checked="" type="checkbox"/> No</p> <p>Lock (if provided)? <input type="checkbox"/> Yes <input type="checkbox"/> No</p>	<p>Measurement: <input type="checkbox"/> Yes <input checked="" type="checkbox"/> No</p>		<p>Photo #:</p> <ul style="list-style-type: none"> • Replace inaccessible knob with lever, loop or push hardware • Add automatic door opener

<p>1.45 Are the operable parts of the door hardware no less than 34 inches and no greater than 48 inches above the floor or ground surface? [404.2.7]</p>	<p>Measurement: <input checked="" type="checkbox"/> Yes <input type="checkbox"/> No</p>		<p>Photo #:</p>	<ul style="list-style-type: none"> • Change hardware height
<p>1.46 If the door has a closer, does it take at least 5 seconds to close from an open position of 90 degrees to a position of 12 degrees from the latch? [404.2.8]</p>	<p>Measurement: <input type="checkbox"/> Yes <input checked="" type="checkbox"/> No</p>		<p>Photo #:</p>	<ul style="list-style-type: none"> • Adjust closer
<p>1.47 If there are two doors in a series, e.g. vestibule, is the distance between the doors at least 48 inches plus the width of the doors when swinging into the space? [404.2.6]</p>	<p>Measurement: <input checked="" type="checkbox"/> Yes <input type="checkbox"/> No 7 feet</p>		<p>Photo #:</p>	<ul style="list-style-type: none"> • Remove inner door • Change door swing

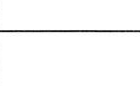
<p>1.48 If provided at the building entrance, are carpets or mats no higher than 1/8 inch thick? [302.2]</p>	<p>Measurement: <input checked="" type="checkbox"/> Yes <input type="checkbox"/> No</p>		<p>Photo #:</p> <ul style="list-style-type: none"> • Replace or remove mats
<p>1.49 Are edges of carpets or mats securely attached to minimize tripping hazards? [302.2]</p>	<p>Measurement: <input checked="" type="checkbox"/> Yes <input type="checkbox"/> No</p>		<p>Photo #:</p> <ul style="list-style-type: none"> • Secure carpeting or mats at edges
<p>Measurement: <input type="checkbox"/> Yes <input type="checkbox"/> No</p>	<p>Measurement: <input type="checkbox"/> Yes <input type="checkbox"/> No</p>		<p>Photo #:</p> <ul style="list-style-type: none"> • • •
<p>Measurement: <input type="checkbox"/> Yes <input type="checkbox"/> No</p>	<p>Measurement: <input type="checkbox"/> Yes <input type="checkbox"/> No</p>		<p>Photo #:</p> <ul style="list-style-type: none"> • • •

ADA Checklist for Existing Facilities

Priority 2 – Access to Goods & Services

Based on the 2010 ADA Standards for Accessible Design

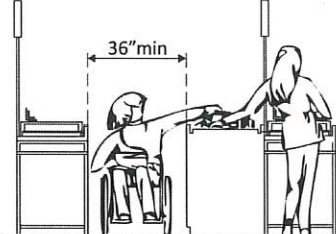

36" min

Project Shelley Senior Center

Building

Location Shelley Maho

Date Jan 23, 2018

Surveyors Susan Lorenz

Contact Information 208-233-4535 x 1



The layout of the building should allow people with disabilities to obtain goods and services and to participate in activities without assistance.

This checklist was produced by the New England ADA Center, a project of the Institute for Human Centered Design and a member of the ADA National Network. This checklist was developed under a grant from the Department of Education, NIDB grant number H133A0002-00A. However the contents do not necessarily represent the policy of the Department of Education, and you should not assume endorsement by the Federal Government.

Questions or comments on the checklist contact the New England ADA Center at 617-495-0085 voice/tty or ADAInfo@NewEnglandADA.org

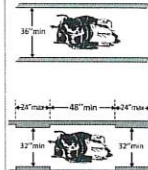
For the full set of checklists, including the checklists for recreation facilities visit www.ADAchecklist.org.

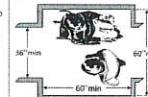
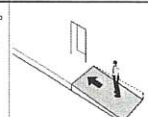
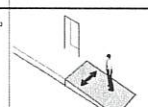
Priority 2 – Access to Goods & Services		Comments	Possible Solutions
2.1	Does the accessible entrance provide direct access to the main floor, lobby and elevator? [See 2010 ADA Standards for Accessible Design – 206.4]	<input checked="" type="checkbox"/> Yes <input type="checkbox"/> No Photo #:	<ul style="list-style-type: none"> Create accessible route
Interior Accessible Route			
2.2	Are all public spaces on at least one accessible route? [206.2.4]	<input checked="" type="checkbox"/> Yes <input type="checkbox"/> No Photo #:	<ul style="list-style-type: none"> Create accessible route
2.3	Is the route stable, firm and slip-resistant? [402.2, 302.1]	<input checked="" type="checkbox"/> Yes <input type="checkbox"/> No Photo #:	<ul style="list-style-type: none"> Repair uneven surfaces
2.4	Is the route at least 36 inches wide? [403.5.1] Note: The accessible route can narrow to 32 inches min. for a max. of 24 inches. These narrower portions of the route must be at least 48 inches from each other.	<input checked="" type="checkbox"/> Yes <input type="checkbox"/> No Measurement:  Photo #:	<ul style="list-style-type: none"> Widen route

2.5	If the route is greater than 200 feet in length and less than 60 inches wide, is there a passing space no less than 60 x 60 inches? [403.5.3]	<input type="checkbox"/> Yes <input type="checkbox"/> No Measurement: 	na Photo #:	<ul style="list-style-type: none"> Widen route for passing space
2.6	Is the running slope no steeper than 1:20, i.e. for every inch of height change there are at least 20 inches of route run? [403.3] Note: If the running slope is steeper than 1:20, treat as a ramp and add features such as edge protection and handrails.	<input type="checkbox"/> Yes <input type="checkbox"/> No Measurement: 	na Photo #:	<ul style="list-style-type: none"> Regrade
2.7	Is the cross slope no steeper than 1:48? [403.3]	<input type="checkbox"/> Yes <input type="checkbox"/> No Measurement: 	na Photo #:	<ul style="list-style-type: none"> Regrade
2.8	Do all objects on circulation paths through public areas, e.g. fire extinguishers, drinking fountains, signs, etc., protrude no more than 4 inches into the path? Or	<input checked="" type="checkbox"/> Yes <input type="checkbox"/> No Measurement: no protrusions 	na Photo #:	<ul style="list-style-type: none"> Remove object Add tactile warning such as permanent planter or partial walls

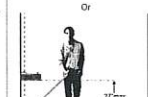
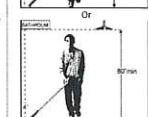
	If an object protrudes more than 4 inches, is the bottom leading edge at 27 inches or lower above the floor? [307.2] Or	<input type="checkbox"/> Yes <input type="checkbox"/> No Measurement: 	Or	<input type="checkbox"/> Yes <input type="checkbox"/> No Measurement: 	na Photo #:	
2.9	Are there elevators or platform lifts to all public stories? Note: Vertical access is not required in new construction or alterations if a facility is less than three stories or has less than 3,000 square feet per story, unless the facility is a shopping center, shopping mall, professional office of a health care provider, transportation terminal, state facility or local government facility	<input type="checkbox"/> Yes <input checked="" type="checkbox"/> No Photo #:				<ul style="list-style-type: none"> Install if necessary Offer goods and services on an accessible story

Ramps				
<p>2.10 If there is a ramp, is it at least 36 inches wide? [405.5]</p> <p>Note: If there are handrails, measure between the handrails.</p>	<p>Measurement: <input type="checkbox"/> Yes <input type="checkbox"/> No</p>		<p>na</p> <p>Photo #:</p>	<ul style="list-style-type: none"> Alter ramp Relocate ramp
<p>2.11 Is the surface stable, firm and slip resistant? [405.4]</p>	<p>Measurement: <input type="checkbox"/> Yes <input type="checkbox"/> No</p>		<p>na</p> <p>Photo #:</p>	<ul style="list-style-type: none"> Resurface ramp
<p>2.12 For each section of the ramp, is the running slope no greater than 1:12, i.e. for every inch of height change there are at least 12 inches of ramp run? [405.2]</p> <p>Note: Rises no greater than 3 inches with a slope no steeper than 1:8 and rises no greater than 6 inches with a slope no steeper than 1:10 are permitted when due to space limitations.</p>	<p>Measurement: <input type="checkbox"/> Yes <input type="checkbox"/> No</p>		<p>na</p> <p>Photo #:</p>	<ul style="list-style-type: none"> Lengthen ramp to decrease slope Relocate ramp

<p>2.13 Is there a level landing that is at least 60 inches long and at least as wide as the ramp?</p> <p>At the top of the ramp?</p> <p>Measurement: <input type="checkbox"/> Yes <input type="checkbox"/> No</p> <p>At the bottom of the ramp? [405.7.2, 405.7.3]</p> <p>Measurement: <input type="checkbox"/> Yes <input type="checkbox"/> No</p>	<p>Measurement: <input type="checkbox"/> Yes <input type="checkbox"/> No</p>		<p>na</p> <p>Photo #:</p>	<ul style="list-style-type: none"> Alter ramp Relocate ramp
<p>2.14 Is there a level landing where the ramp changes direction that is at least 60 x 60 inches? [405.7.4]</p>	<p>Measurement: <input type="checkbox"/> Yes <input type="checkbox"/> No</p> <p>NA</p>		<p>na</p> <p>Photo #:</p>	<ul style="list-style-type: none"> Increase landing size
<p>2.15 If the ramp has a rise higher than 6 inches are there handrails on both sides? [405.5]</p>	<p>Measurement: <input type="checkbox"/> Yes <input type="checkbox"/> No</p>		<p>na</p> <p>Photo #:</p>	<ul style="list-style-type: none"> Add handrails

<p>2.16 Is the top of the handrail gripping surface no less than 34 inches and no greater than 38 inches above the ramp surface? [505.4]</p>	<p>Measurement: <input type="checkbox"/> Yes <input type="checkbox"/> No</p>		<p>na</p> <p>Photo #:</p>	<ul style="list-style-type: none"> Adjust handrail height
<p>2.17 Is the handrail gripping surface continuous and not obstructed along the top or sides? [505.5]</p> <p>If there are obstructions, is the bottom of the gripping surface obstructed no more than 20%? [505.6]</p>	<p>Measurement: <input type="checkbox"/> Yes <input type="checkbox"/> No</p> <p>NA</p>		<p>na</p> <p>Photo #:</p>	<ul style="list-style-type: none"> Reconfigure or replace handrails
<p>2.18 If the handrail gripping surface is circular, is it no less than 1 1/4 inches and no greater than 2 inches in diameter? [505.7.1]</p>	<p>Measurement: <input type="checkbox"/> Yes <input type="checkbox"/> No</p>		<p>na</p> <p>Photo #:</p>	<ul style="list-style-type: none"> Replace handrails
<p>2.19 If the handrail gripping surface is non-circular:</p> <p>Is the perimeter no less than 4 inches and no greater than 6 1/2 inches?</p> <p>Is the cross section no greater than 2 1/4 inches in diameter? [505.7.2]</p>	<p>Measurement: <input type="checkbox"/> Yes <input type="checkbox"/> No</p> <p>Measurement: <input type="checkbox"/> Yes <input type="checkbox"/> No</p>		<p>na</p> <p>Photo #:</p>	<ul style="list-style-type: none"> Replace handrails

<p>2.20 Does the handrail:</p> <p>Extend at least 12 inches horizontally beyond the top and bottom of the ramp?</p> <p>Return to a wall, guard, or landing surface? [505.10.1]</p> <p>Note: If a 12" extension would be hazardous (in circulation path), it is not required.</p>	<p>Measurement: <input type="checkbox"/> Yes <input type="checkbox"/> No</p> <p>Measurement: <input type="checkbox"/> Yes <input type="checkbox"/> No</p>		<p>na</p> <p>Photo #:</p>	<ul style="list-style-type: none"> Alter handrails
<p>2.21 To prevent wheelchair casters and crutch tips from falling off:</p> <p>Does the surface of the ramp extend at least 12 inches beyond the inside face of the handrail?</p> <p>Or</p> <p>Is there a curb or barrier that prevents the passage of a 4-inch diameter sphere? [405.9.1, 405.9.2]</p>	<p>Measurement: <input type="checkbox"/> Yes <input type="checkbox"/> No</p> <p>Measurement: <input type="checkbox"/> Yes <input type="checkbox"/> No</p>		<p>na</p> <p>Photo #:</p>	<ul style="list-style-type: none"> Add curb Add barrier Extend ramp width
<p>Elevators – Full Size & LULA (limited use, limited application) LULA elevators are often used in alterations.</p> <p>2.22 If there is a full size or LULA elevator, are the call buttons no higher than 54 inches above the floor? [407.2.1.1]</p>	<p>Measurement: <input type="checkbox"/> Yes <input type="checkbox"/> No</p>		<p>na</p> <p>Photo #:</p>	<ul style="list-style-type: none"> Change call button height

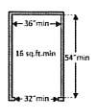

Priority 2 – Access to Goods & Services

<p>2.23 If there is a full size or LULA elevator, does the sliding door reopen automatically when obstructed by an object or person? [407.3.3]</p>	<p><input type="checkbox"/> Yes <input type="checkbox"/> No</p>		<p>na</p> <p>Photo #:</p> <p>* If constructed before 3/15/2012 and manually operated, the door is not required to reopen automatically</p> <ul style="list-style-type: none"> • Install opener
<p>2.24 If there is a LULA elevator with a swinging door:</p> <p>Is the door power-operated?</p> <p>Does the door remain open for at least 20 seconds when activated? [403.3.2]</p>	<p><input type="checkbox"/> Yes <input type="checkbox"/> No</p> <p>Time:</p>		<p>na</p> <p>Photo #:</p> <ul style="list-style-type: none"> • Add power-operated door • Adjust opening time
<p>2.25 If there is a full size elevator:</p> <p>Is the interior at least 54 inches deep by at least 36 inches wide with at least 16 sq. ft. of clear floor area?</p> <p>Is the door opening width at least 32 inches? [407.4.1 Exception]</p>	<p><input type="checkbox"/> Yes <input type="checkbox"/> No</p> <p>Measurement:</p> <p><input type="checkbox"/> Yes <input type="checkbox"/> No</p> <p>Measurement:</p>		<p>na</p> <p>Photo #:</p> <ul style="list-style-type: none"> • Replace elevator

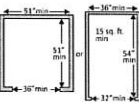
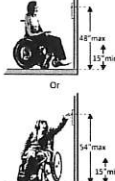

Priority 2 – Access to Goods & Services

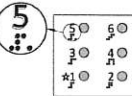

<p>2.26 If there is a LULA elevator, is the interior:</p> <p>At least 51 inches deep by 51 inches wide with a door opening width of at least 36 inches?</p> <p>Or</p> <p>At least 54 inches deep by at least 36 inches wide with at least 15 sq. ft. of clear floor area and a door opening width of at least 32 inches? [408.4.1 Exceptions 1 and 2]</p>	<p><input type="checkbox"/> Yes <input type="checkbox"/> No</p> <p>Measurement:</p> <p><input type="checkbox"/> Yes <input type="checkbox"/> No</p> <p>Measurement:</p>		<p>na</p> <p>Photo #:</p> <ul style="list-style-type: none"> • Replace elevator
<p>2.27 If there is a full size or LULA elevator, are the in-car controls:</p> <p>No less than 15 inches and no greater 48 inches above the floor?</p> <p>Or</p> <p>Up to 54 inches above the floor for a parallel approach? [408.4.6, 407.4.6.1]</p>	<p><input type="checkbox"/> Yes <input type="checkbox"/> No</p> <p>Measurement:</p> <p><input type="checkbox"/> Yes <input type="checkbox"/> No</p> <p>Measurement:</p>		<p>na</p> <p>Photo #:</p> <ul style="list-style-type: none"> • Change control height

Priority 2 – Access to Goods & Services

<p>2.28 If there is a LULA elevator, are the in-car controls centered on a side wall? [408.4.6]</p>	<p><input type="checkbox"/> Yes <input type="checkbox"/> No</p> <p>Measurement:</p>		<p>na</p> <p>Photo #:</p> <ul style="list-style-type: none"> • Reconfigure controls
<p>2.29 If there is a full size or LULA elevator:</p> <p>Are the car control buttons designated with raised characters?</p> <p>Are the car control buttons designated with Braille? [407.4.7.1, 703.2]</p>	<p><input type="checkbox"/> Yes <input type="checkbox"/> No</p> <p><input type="checkbox"/> Yes <input type="checkbox"/> No</p>		<p>na</p> <p>Photo #:</p> <ul style="list-style-type: none"> • Add raised characters • Add Braille
<p>2.30 If there is a full size or LULA elevator, are there audible signals which sound as the car passes or is about to stop at a floor? [407.4.8]</p>	<p><input type="checkbox"/> Yes <input type="checkbox"/> No</p>		<p>na</p> <p>Photo #:</p> <ul style="list-style-type: none"> • Install audible signals
<p>2.31 If there is a full size or LULA elevator:</p> <p>Is there a sign on both door jambs at every floor identifying the floor?</p> <p>Is there a tactile star on both jambs at the main entry level?</p> <p>Do text characters contrast with their backgrounds?</p>	<p><input type="checkbox"/> Yes <input type="checkbox"/> No</p> <p><input type="checkbox"/> Yes <input type="checkbox"/> No</p> <p><input type="checkbox"/> Yes <input type="checkbox"/> No</p>		<p>na</p> <p>Photo #:</p> <ul style="list-style-type: none"> • Install signs • Change sign height

Priority 2 – Access to Goods & Services

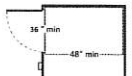
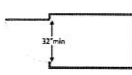

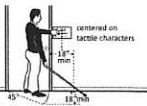

<p>Are text characters raised?</p> <p>Is there Braille?</p> <p>Is the sign mounted between 48 inches to the baseline of the lowest character and 60 inches to the baseline of the highest character above the floor? [407.2.3, 408.2.3]</p>	<p><input type="checkbox"/> Yes <input type="checkbox"/> No</p> <p><input type="checkbox"/> Yes <input type="checkbox"/> No</p> <p><input type="checkbox"/> Yes <input type="checkbox"/> No</p> <p>Measurement:</p>		<p>na</p> <p>Photo #:</p> <ul style="list-style-type: none"> • If constructed before 3/15/2012 and mounted no higher than 60 inches to the centerline of the sign, relocation is not required
<p>Platform Lifts</p> <p>2.32 If a lift is provided, can it be used without assistance from others? [410.1]</p>	<p><input type="checkbox"/> Yes <input type="checkbox"/> No</p>		<p>na</p> <p>Photo #:</p> <ul style="list-style-type: none"> • Reconfigure so independently operable
<p>2.33 Is there a clear floor space at least 30 inches wide by at least 48 inches long for a person using a wheelchair to approach and reach the controls to use the lift? [410.5]</p>	<p><input type="checkbox"/> Yes <input type="checkbox"/> No</p> <p>Measurement:</p>		<p>na</p> <p>Photo #:</p> <ul style="list-style-type: none"> • Remove obstructions

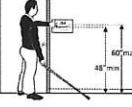
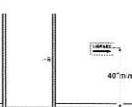

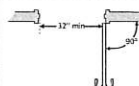
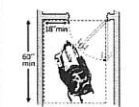

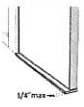
<p>2.34 Are the lift controls no less than 15 inches and no greater than 48 inches above the floor? [410.5]</p>	<p><input type="checkbox"/> Yes <input type="checkbox"/> No Measurement:</p>		<p>no lift in facility Photo #:</p>	<ul style="list-style-type: none"> Change control height
<p>2.35 Is there a clear floor space at least 36 inches wide by at least 48 inches long inside the lift? [410.3]</p>	<p><input type="checkbox"/> Yes <input type="checkbox"/> No Measurement:</p>		<p>Photo #:</p>	<ul style="list-style-type: none"> Replace lift
<p>2.36 If there is an end door, is the clear opening width at least 32 inches? [410.6]</p>	<p><input type="checkbox"/> Yes <input type="checkbox"/> No Measurement:</p>		<p>Photo #:</p>	<ul style="list-style-type: none"> Alter door width
<p>2.37 If there is a side door, is the clear opening width at least 42 inches? [410.6]</p>	<p><input type="checkbox"/> Yes <input type="checkbox"/> No Measurement:</p>		<p>Photo #:</p>	<ul style="list-style-type: none"> Alter door width

<p>Signs "Tactile characters" are read using touch, i.e. raised characters and Braille.</p>					
<p>2.38 If there are signs designating permanent rooms and spaces not likely to change over time, e.g. room numbers and letters, room names, and exit signs: [216.2]</p>	<p><input type="checkbox"/> Yes <input type="checkbox"/> No</p>	<p>na</p>	<p>Photo #:</p>	<ul style="list-style-type: none"> Install tactile sign Relocate sign 	
<p>Do text characters contrast with their backgrounds? [703.5]</p>	<p><input type="checkbox"/> Yes <input type="checkbox"/> No</p>				
<p>Are text characters raised? [703.2]</p>	<p><input type="checkbox"/> Yes <input type="checkbox"/> No</p>				
<p>Is there Braille? [703.3]</p>	<p><input type="checkbox"/> Yes <input type="checkbox"/> No</p>				
<p>Is the sign mounted: On the wall on the latch side of the door? [703.4.2]</p>	<p><input type="checkbox"/> Yes <input type="checkbox"/> No</p>				
<p>Note: Signs are permitted on the push side of doors with closers and without hold-open devices.</p>	<p><input type="checkbox"/> Yes <input type="checkbox"/> No</p>				
<p>With clear floor space beyond the arc of the door swing between the closed position and 45-degree open position, at least 18 x 18 inches centered on the tactile characters? [703.4.2]</p>	<p>Measurement:</p>				
<p>Institute for Human Centered Design 2014</p>	<p>www.ADAchecklist.org</p>	<p>Priority 2 – Access to Goods & Services</p>		<p>Page 15</p>	

<p>So the baseline of the lowest character is at least 48 inches above the floor and the baseline of the highest character is no more than 60 inches above the floor? * [703.4.1]</p> <p>Note: If the sign is at double doors with one active leaf, the sign should be on the inactive leaf; if both leaves are active, the sign should be on the wall to the right of the right leaf.</p>	<p><input type="checkbox"/> Yes <input type="checkbox"/> No Measurement:</p>		<p>Photo #:</p>	<p>*If constructed before 3/15/2012 and mounted no higher than 60 inches to the centerline of the sign, relocation not required</p>
<p>2.39 If there are signs that provide direction to or information about interior spaces: Do text characters contrast with their backgrounds? [703.5.1]</p> <p>Is the sign mounted so that characters are at least 40 inches above the floor? [703.5.6]</p> <p>Note: Raised characters and Braille are not required.</p>	<p><input type="checkbox"/> Yes <input type="checkbox"/> No <input type="checkbox"/> Yes <input type="checkbox"/> No Measurement:</p>		<p>Photo #:</p>	<ul style="list-style-type: none"> Install signs with contrasting characters Change sign height

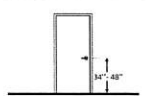
<p>Interior Doors – to classrooms, medical exam rooms, conference rooms, etc.</p>					
<p>2.40 Is the door opening width at least 32 inches clear, between the face of the door and the stop, when the door is open 90 degrees? [404.2.3]</p>	<p><input type="checkbox"/> Yes <input type="checkbox"/> No Measurement:</p>		<p>Photo #:</p>	<ul style="list-style-type: none"> Install offset hinges Alter the doorway 	
<p>2.41 If there is a front approach to the pull side of the door, is there at least 18 inches of maneuvering clearance beyond the latch side plus at least 60 inches clear depth?</p> <p>Note: See 2010 Standards 404.2.4 for maneuvering clearance requirements on the push side of the door and side approaches to the pull side of the door.</p> <p>On both sides of the door, is the floor surface of the maneuvering clearance level (no steeper than 1:48)? [404.2.4]</p>	<p><input type="checkbox"/> Yes <input type="checkbox"/> No Measurement:</p>		<p>Photo #:</p>	<ul style="list-style-type: none"> Remove obstructions Reconfigure walls Add automatic door opener 	
<p>Institute for Human Centered Design 2014</p>	<p>www.ADAchecklist.org</p>	<p>Priority 2 – Access to Goods & Services</p>		<p>Page 17</p>	

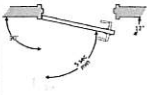
<p>2.42 If the threshold is vertical is it no more than 1/4 inch high? Or No more than 1/2 inch high with the top 1/4 inch beveled no steeper than 1:2, if the threshold was installed on or after the 1991 ADA Standards went into effect (1/26/93)? Or No more than 3/4 inch high with the top 1/2 inch beveled no steeper than 1:2, if the threshold was installed before the 1991 ADA Standards went into effect (1/26/93)? [404.2.5, 303.2] Note: The first 1/4 inch of the 3/4 or 1/2 inch threshold may be vertical; the rest must be beveled.</p>	<p><input type="checkbox"/> Yes <input type="checkbox"/> No Measurement:</p>  <p>1/4" max</p> <p><input type="checkbox"/> Yes <input type="checkbox"/> No Measurement:</p>  <p>1/2" max</p> <p><input type="checkbox"/> Yes <input type="checkbox"/> No Measurement:</p>  <p>3/4" max</p>	<p>na no such areas</p> <p>Photo #:</p>	<ul style="list-style-type: none"> Remove or replace threshold
<p>2.43 Is the door equipped with hardware that is operable with one hand and does not require tight grasping, pinching or twisting of the wrist? Door handle? Lock (if provided)? [404.2.7]</p>	<p><input type="checkbox"/> Yes <input type="checkbox"/> No</p>  <p><input type="checkbox"/> Yes <input type="checkbox"/> No</p> <p><input type="checkbox"/> Yes <input type="checkbox"/> No</p>	<p>na</p> <p>Photo #:</p>	<ul style="list-style-type: none"> Replace inaccessible knob with lever, loop or push hardware Add automatic door opener

<p>2.44 Are the operable parts of the hardware no less than 34 inches and no greater than 48 inches above the floor? [404.2.7]</p>	<p><input type="checkbox"/> Yes <input type="checkbox"/> No Measurement:</p>  <p>Photo #:</p>	<p>na</p>	<ul style="list-style-type: none"> Change hardware height
<p>2.45 Can the door be opened easily (5 pounds maximum force)? [404.2.9] Note: You can use a pressure gauge or fish scale to measure force. If you do not have one you will need to judge whether the door is easy to open.</p>	<p><input type="checkbox"/> Yes <input type="checkbox"/> No Measurement:</p>  <p>Photo #:</p>	<p>na</p>	<ul style="list-style-type: none"> Adjust or replace closers Install lighter doors Install power-assisted or automatic door openers
<p>2.46 If the door has a closer, does it take at least 5 seconds to close from an open position of 90 degrees to a position of 12 degrees from the latch? [404.2.8.1]</p>	<p><input type="checkbox"/> Yes <input type="checkbox"/> No Measurement:</p>  <p>Photo #:</p>	<p>na</p>	<ul style="list-style-type: none"> Adjust closer
<p>Rooms and Spaces – stores, supermarkets, libraries, etc.</p>			
<p>2.47 Are aisles and pathways to goods and services, and to one of each type of sales and service counters, at least 36 inches wide? [403.5.1]</p>	<p><input checked="" type="checkbox"/> Yes <input type="checkbox"/> No Measurement:</p>  <p>Photo #:</p>	<p>na</p>	<ul style="list-style-type: none"> Rearrange goods, equipment and furniture

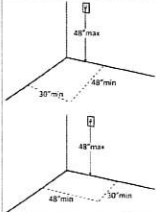
<p>2.48 Are floor surfaces stable, firm and slip resistant? [302.1]</p>	<p><input checked="" type="checkbox"/> Yes <input type="checkbox"/> No</p>	<p>Photo #:</p>	<ul style="list-style-type: none"> Change floor surface
<p>2.49 If there is carpet: Is it no higher than 1/8 inch? Is it securely attached along the edges? [302.2]</p>	<p><input type="checkbox"/> Yes <input type="checkbox"/> No Measurement:</p>  <p>1/8" max</p> <p><input type="checkbox"/> Yes <input type="checkbox"/> No</p>	<p>no carpet</p> <p>Photo #:</p>	<ul style="list-style-type: none"> Replace carpet
<p>Controls – light switches, security and intercom systems, emergency/alarm boxes, etc.</p>			
<p>2.50 Is there a clear floor space at least 30 inches wide by at least 48 inches long for a forward or parallel approach? [305.3] Are the operable parts no higher than 48 inches above the floor? [309.3, 308]</p>	<p><input checked="" type="checkbox"/> Yes <input type="checkbox"/> No Measurement: 48x60</p> <p><input type="checkbox"/> Yes <input checked="" type="checkbox"/> No Measurement: 50 inches</p>  <p>48" max 30" min 48" min 30" min</p>	<p>Photo #:</p>	<ul style="list-style-type: none"> Change height of control <p>*If constructed before 3/15/2012 and a parallel approach is provided, controls can be 54 inches above the floor</p>

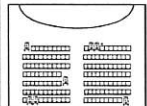
<p>2.51 Can the control be operated with one hand and without tight grasping, pinching, or twisting of the wrist? [309.4]</p>	<p><input type="checkbox"/> Yes <input checked="" type="checkbox"/> No</p>  <p>Photo #:</p>	<p>just traditional switches but the seniors are not expected to use these switches. Staff turns them on and off when the center is opened.</p>	<ul style="list-style-type: none"> Replace control no correction recommended 												
<p>Seating: Assembly Areas – theaters, auditoriums, stadiums, theater style classrooms, etc.</p>															
<p>2.52 Are an adequate number of wheelchair spaces provided? [221.2.1]</p>	<p><input type="checkbox"/> Yes <input type="checkbox"/> No</p> <table border="1"> <tr> <th># of Seats</th> <th>Wheelchair Spaces</th> </tr> <tr> <td>4 - 25</td> <td>1</td> </tr> <tr> <td>26 - 50</td> <td>2</td> </tr> <tr> <td>51 - 150</td> <td>4</td> </tr> <tr> <td>151 - 300</td> <td>5</td> </tr> <tr> <td colspan="2">300+ see 2010 Standards 221.2.1.</td> </tr> </table> <p>Total #: Wheelchair #:</p>	# of Seats	Wheelchair Spaces	4 - 25	1	26 - 50	2	51 - 150	4	151 - 300	5	300+ see 2010 Standards 221.2.1.		<p>na this is an eating space and all tables have a space that fits wheelchairs.</p> <p>Photo #:</p>	<ul style="list-style-type: none"> Reconfigure to add wheelchair spaces
# of Seats	Wheelchair Spaces														
4 - 25	1														
26 - 50	2														
51 - 150	4														
151 - 300	5														
300+ see 2010 Standards 221.2.1.															
<p>2.53 Are wheelchair spaces dispersed to allow location choices and viewing angles equivalent to other seating, including specialty seating areas that provide distinct services and amenities? [221.2.3]</p>	<p><input type="checkbox"/> Yes <input type="checkbox"/> No</p>  <p>Photo #:</p>	<p>na</p>	<ul style="list-style-type: none"> Reconfigure to disperse wheelchair spaces 												

Priority 2 – Access to Goods & Services

<p>2.54 Where people are expected to remain seated, do people in wheelchair spaces have a clear line of sight over and between the heads of others in front of them? [802.2.1.1, 802.1.1.2]</p>	<p><input type="checkbox"/> Yes <input type="checkbox"/> No</p>		<p>Photo #:</p> <ul style="list-style-type: none"> Alter for line of sight
<p>2.55 Where people are expected to stand, do people in wheelchair spaces have a clear line of sight over and between the heads of others in front of them? [802.2.2.1, 802.1.2.2]</p>	<p><input type="checkbox"/> Yes <input type="checkbox"/> No</p>		<p>Photo #:</p> <ul style="list-style-type: none"> Alter for line of sight
<p>2.56 If there is a single wheelchair space, is it at least 36 inches wide? [802.1.2]</p>	<p><input type="checkbox"/> Yes <input type="checkbox"/> No Measurement:</p>		<p>Photo #:</p> <ul style="list-style-type: none"> Alter space
<p>2.57 If there are two adjacent wheelchair spaces, are they each at least 33 inches wide? [802.1.2]</p>	<p><input type="checkbox"/> Yes <input type="checkbox"/> No Measurement:</p>		<p>Photo #:</p> <ul style="list-style-type: none"> Alter spaces

Priority 2 – Access to Goods & Services

<p>2.58 If the wheelchair space can be entered from the front or rear, is it at least 48 inches deep? [802.1.3]</p>	<p><input type="checkbox"/> Yes <input type="checkbox"/> No Measurement:</p>		<p>Photo #:</p> <ul style="list-style-type: none"> Alter space
<p>2.59 If the wheelchair space can only be entered from the side, is it at least 60 inches deep? [802.1.3]</p>	<p><input type="checkbox"/> Yes <input type="checkbox"/> No Measurement:</p>		<p>Photo #:</p> <ul style="list-style-type: none"> Alter space
<p>2.60 Do wheelchair spaces adjoin, but not overlap, accessible routes? [802.1.4]</p>	<p><input type="checkbox"/> Yes <input type="checkbox"/> No Accessible Route</p>		<p>Photo #:</p> <ul style="list-style-type: none"> Alter spaces
<p>2.61 Is there at least one companion seat for each wheelchair space? [221.3]</p>	<p><input type="checkbox"/> Yes <input type="checkbox"/> No</p>		<p>Photo #:</p> <ul style="list-style-type: none"> Add companion seats

Priority 2 – Access to Goods & Services



<p>2.62 Is the companion seat located so the companion is shoulder-to-shoulder with the person in a wheelchair? [802.3.1]</p>	<p><input type="checkbox"/> Yes <input type="checkbox"/> No</p>		<p>Photo #:</p> <ul style="list-style-type: none"> Alter seating
<p>2.63 Is the companion seat equivalent in size, quality, comfort and amenities to seating in the immediate area? [802.3.2]</p>	<p><input type="checkbox"/> Yes <input type="checkbox"/> No</p>		<p>Photo #:</p> <ul style="list-style-type: none"> Add equivalent seating
<p>Seating: At dining surfaces (restaurants, cafeterias, bars, etc.) and non-employee work surfaces (libraries, conference rooms, etc.)</p>			
<p>2.64 Are at least 5%, but no fewer than one, of seating and standing spaces accessible for people who use wheelchairs? [226.3]</p>	<p><input checked="" type="checkbox"/> Yes <input type="checkbox"/> No Total #: 85 Wheelchair #: 12</p>		<p>Photo #:</p> <ul style="list-style-type: none"> Alter to provide accessible spaces
<p>2.65 Is there a route at least 36 inches wide to accessible seating? [403.5.1]</p>	<p><input checked="" type="checkbox"/> Yes <input type="checkbox"/> No Measurement:</p>		<p>Photo #:</p> <ul style="list-style-type: none"> Widen route

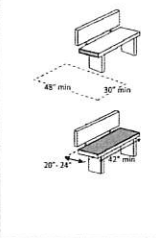

Priority 2 – Access to Goods & Services

<p>2.66 At the accessible space(s), is the top of the accessible surface no less than 28 inches and no greater than 34 inches above the floor? [902.3]</p>	<p><input checked="" type="checkbox"/> Yes <input type="checkbox"/> No Measurement: 29 inches</p>		<p>Photo #:</p> <ul style="list-style-type: none"> Alter surface height
<p>2.67 Is there a clear floor space at least 30 inches wide by at least 48 inches long for a forward approach? [305.3]</p>	<p><input checked="" type="checkbox"/> Yes <input type="checkbox"/> No Measurement:</p>		<p>Photo #:</p> <ul style="list-style-type: none"> Alter table or work surface Add accessible table or work surface
<p>Does it extend no less than 17 inches and no greater than 25 inches under the surface?</p>	<p><input checked="" type="checkbox"/> Yes <input type="checkbox"/> No Measurement:</p>		
<p>Is there knee space at least 27 inches high and at least 30 inches wide? [306.2, 306.3]</p>	<p><input checked="" type="checkbox"/> Yes <input type="checkbox"/> No Measurement:</p>		<p>Photo #:</p> <ul style="list-style-type: none"> Add companion seats
<p>Note: if for children, the knee space may be 24 inches high.</p>			

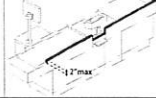

Seating: General – reception areas, waiting rooms, etc.

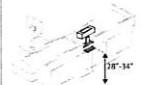

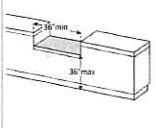
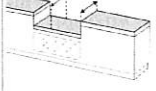
<p>2.68 Is there at least one space at least 36 inches wide by at least 48 inches long for a person in a wheelchair? [802.1.2, 802.1.3]</p>	<p><input checked="" type="checkbox"/> Yes <input type="checkbox"/> No Measurement: 36</p>		<p>Photo #:</p> <ul style="list-style-type: none"> • Move furniture and equipment to provide space
<p>Benches – In locker rooms, dressing rooms, fitting rooms This section does not apply to any other benches.</p>			
<p>2.69 In locker rooms, dressing rooms and fitting rooms, is there at least one room with a bench? [222.3, 803.4]</p>	<p><input type="checkbox"/> Yes <input type="checkbox"/> No</p>	<p>name</p>	<p>Photo #:</p> <ul style="list-style-type: none"> • Add bench
<p>2.70 Is there a clear floor space at least 30 inches wide by at least 48 inches long at the end of the bench and parallel to the short axis of the bench? Is the bench seat at least 42 inches long and no less than 20 inches and no greater than 24 inches deep? Does the bench have back support or is it affixed to a wall? Is the top of the bench seat no less than 17 inches and no greater than 19 inches above the floor? [90.3]</p>	<p><input type="checkbox"/> Yes <input type="checkbox"/> No Measurement: <input type="checkbox"/> Yes <input type="checkbox"/> No Measurement: <input type="checkbox"/> Yes <input type="checkbox"/> No Measurement: <input type="checkbox"/> Yes <input type="checkbox"/> No Measurement:</p>		<p>Photo #:</p> <ul style="list-style-type: none"> • Move bench • Replace bench • Affix bench to wall

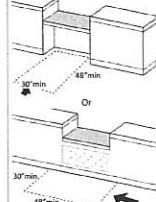
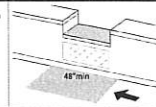
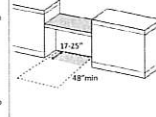

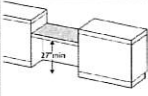
			<p>Photo #:</p>
<p>Check-Out Aisles – supermarkets, large retail stores, etc.</p>			
<p>2.71 Is the aisle at least 36 inches wide? [904.3.1]</p>	<p><input checked="" type="checkbox"/> Yes <input type="checkbox"/> No Measurement:</p>		<p>Photo #:</p> <ul style="list-style-type: none"> • no check out idles • Widen aisle
<p>2.72 Is the counter surface of at least one aisle no higher than 38 inches above the floor? [904.3.2]</p>	<p><input checked="" type="checkbox"/> Yes <input type="checkbox"/> No Measurement:</p>		<p>Photo #:</p> <ul style="list-style-type: none"> • Lower counter
<p>2.73 Is the top of the counter edge protection no higher than 2 inches above the counter surface? [904.3.2]</p>	<p><input checked="" type="checkbox"/> Yes <input type="checkbox"/> No Measurement: 0</p>		<p>Photo #:</p> <ul style="list-style-type: none"> • Lower edge protection

<p>2.74 If there is a check writing surface, is the top no less than 28 inches and no greater than 34 inches above the floor? [904.3.3]</p>	<p><input checked="" type="checkbox"/> Yes <input type="checkbox"/> No Measurement:</p>		<p>Photo #:</p> <ul style="list-style-type: none"> • Alter check writing surface
<p>2.75 If there is more than one check-out aisle is there a sign with the International Symbol of Accessibility at the accessible aisle? [216.11]</p>	<p><input type="checkbox"/> Yes <input type="checkbox"/> No</p>		<p>Photo #:</p> <ul style="list-style-type: none"> • Add sign
<p>Sales & Service Counters – banks, stores, dry cleaners, auto repair shops, fitness clubs, etc.</p>			
<p>2.76 Is there a portion of at least one of each type of counter that is: No higher than 36 inches above the floor? At least 36 inches long? [904.4.1]</p>	<p><input checked="" type="checkbox"/> Yes <input type="checkbox"/> No Measurement: <input checked="" type="checkbox"/> Yes <input type="checkbox"/> No Measurement:</p>		<p>Photo #:</p> <ul style="list-style-type: none"> • Lower section of counter • Lengthen section of counter
<p>2.77 Does the accessible portion of the counter extend the same depth as the counter top? [904.4]</p>	<p><input checked="" type="checkbox"/> Yes <input type="checkbox"/> No Measurement:</p>		<p>Photo #:</p> <ul style="list-style-type: none"> • Alter accessible portion

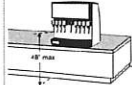
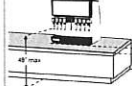
<p>2.78 Is there a clear floor space at least 30 inches wide by at least 48 inches long for a forward or parallel approach? [904.4]</p>	<p><input checked="" type="checkbox"/> Yes <input type="checkbox"/> No <input checked="" type="checkbox"/> Parallel Measurement: 48" <input checked="" type="checkbox"/> Forward Measurement: 48"</p>		<p>Photo #:</p> <ul style="list-style-type: none"> • Reconfigure to provide a parallel or forward approach
<p>2.79 For a parallel approach, is the clear floor space positioned with the 48 inches adjacent to the accessible length of counter? [904.4.1]</p>	<p><input checked="" type="checkbox"/> Yes <input type="checkbox"/> No Measurement: 48</p>		<p>Photo #:</p> <ul style="list-style-type: none"> • If a parallel approach is not possible, a forward approach is required
<p>2.80 For a forward approach: Do no less than 17 and no greater than 25 inches of the clear floor space extend under the accessible length of the counter? [306.2.2, 306.2.3]</p> <p>Is there at least 27 inches:</p>	<p><input type="checkbox"/> Yes <input checked="" type="checkbox"/> No Measurement: <input checked="" type="checkbox"/> Yes <input type="checkbox"/> No</p>		<p>Photo #:</p> <ul style="list-style-type: none"> • Reconfigure to provide knee clearance

clearance from the floor to the bottom of the counter? [306.3.1]	Measurement: 32"		Photo #:	
Food Service Lines – In cafeterias, salad bars, eat-in fast food establishments, etc.				
2.81 Does at least one of each type of self-service shelf or dispensing device for tableware, dishware, condiments, food and beverages have a forward or parallel approach? [904.5.1]	<input type="checkbox"/> Yes <input type="checkbox"/> No <input type="checkbox"/> Forward <input type="checkbox"/> Parallel	 Or 	food is brought at tables, no food service line • Reconfigure to provide approach •	Photo #:

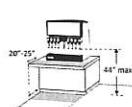
2.82 If there is an unobstructed parallel approach, is the shelf or dispensing device no higher than 48 inches above the floor? [308.3.1]	<input type="checkbox"/> Yes <input checked="" type="checkbox"/> No	Measurement: 34		separate coffee area	• Lower shelf and/or dispensing device •
2.83 If there is a shallow obstruction no deeper than 10 inches with a parallel approach, is the shelf or dispensing device no higher than 48 inches above the floor? [308.3.1]	<input checked="" type="checkbox"/> Yes <input type="checkbox"/> No	Measurement: 7 inches			• Lower shelf and/or dispensing device •
2.84 If there is an obstruction no less than 30 inches and no greater than 24 inches deep with a parallel approach, is the shelf or dispensing device no higher than 46 inches above the floor? [308.3.2]	<input checked="" type="checkbox"/> Yes <input type="checkbox"/> No	Measurement: 31			• Lower shelf and/or dispensing device •
2.85 If there is an unobstructed forward approach, is the shelf or dispensing device no higher than 48 inches above the floor? [308.2.1]	<input checked="" type="checkbox"/> Yes <input type="checkbox"/> No	Measurement: 34			• Lower shelf and/or dispensing device •

2.86 If there is an obstruction no deeper than 20 inches with a forward approach: Does clear floor space extend under the obstruction that is at least the same depth as the obstruction? Is the shelf or dispensing device no higher than 48 inches above the floor? [904.5.1]	<input type="checkbox"/> Yes <input checked="" type="checkbox"/> No Measurement: 0 <input checked="" type="checkbox"/> Yes <input type="checkbox"/> No Measurement: 33		Photo #:	• Reconfigure to provide knee space • Lower shelf and/or dispensing device •
2.87 If the obstruction is no less than 20 inches and no greater than 25 inches deep with a forward approach: Does clear floor space extend under the obstruction that is at least the same depth as the obstruction? Is the shelf or dispensing device no higher than 44 inches above the floor? [904.5.1]	<input type="checkbox"/> Yes <input checked="" type="checkbox"/> No Measurement: 0 <input checked="" type="checkbox"/> Yes <input type="checkbox"/> No Measurement: 33		Photo #:	• Reconfigure to provide knee space • Lower shelf and/or dispensing device •
2.88 If there is a tray slide, is the top no less than 28 inches and no greater than 34 inches above the floor? [904.5.2]	<input type="checkbox"/> Yes <input type="checkbox"/> No	Measurement:		no tray slide • Reconfigure •

<input type="checkbox"/> Yes <input type="checkbox"/> No				
<input type="checkbox"/> Yes <input type="checkbox"/> No			Photo #:	
<input type="checkbox"/> Yes <input type="checkbox"/> No			Photo #:	
<input type="checkbox"/> Yes <input type="checkbox"/> No			Photo #:	
<input type="checkbox"/> Yes <input type="checkbox"/> No			Photo #:	

The ADA Checklist for Existing Facilities

Priority 3 - Toilet Rooms

Based on the 2010 ADA Standards for Accessible Design

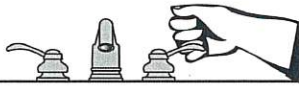

Project Shelley Senior Center
 Building _____
 Location Shelley Idaho _____
 Date January 23, 2018 _____
 Surveyors Susan Lorenz _____
 Contact Information 208-233-4535 x 1 _____

When toilet rooms are open to the public they should be accessible to people with disabilities.



This checklist was produced by the New England ADA Center, a project of the Institute for Human Centered Design and a member of the ADA National Network. This checklist was developed under a grant from the Department of Education, NIDRR grant number H133A060092-09A. However the contents do not necessarily represent the policy of the Department of Education, and you should not assume endorsement by the Federal Government.

Questions or comments on the checklist contact the New England ADA Center at 617-695-0085 voice/tty or ADAInfo@NewEnglandADA.org

For the full set of checklists, including the checklists for recreation facilities visit www.ADAchecklist.org.

Priority 3 – Toilet Rooms	Comments	Possible Solutions
<p>3.1 If toilet rooms are available to the public, is at least one toilet room accessible? [Either one for each sex, or one unisex.]</p> <p>Note: If toilet rooms are chiefly for children, e.g., in elementary schools and day care centers, use the children's specifications in Toilets - 604.1, 604.8, 604.9, 609.4 and Lavatories and Sinks - 606.2.</p> <p><input checked="" type="checkbox"/> Yes <input type="checkbox"/> No</p>		<ul style="list-style-type: none"> Reconfigure toilet rooms Combine toilet rooms to create one unisex accessible toilet room
<p>3.2 Are there signs at inaccessible toilet rooms that give directions to accessible toilet rooms? [See 2010 ADA Standards for Accessible Design - 216.8]</p> <p><input type="checkbox"/> Yes <input type="checkbox"/> No</p>	<p>Photo #:</p>	<ul style="list-style-type: none"> Install signs
<p>3.3 If not all toilet rooms are accessible, is there a sign at the accessible toilet room with the International Symbol of Accessibility? [216.8]</p> <p><input type="checkbox"/> Yes <input type="checkbox"/> No</p>	<p>Photo #:</p>	<ul style="list-style-type: none"> Install sign

<p>3.4 Is there an accessible route to the accessible toilet room? [206.2.4]</p> <p><input checked="" type="checkbox"/> Yes <input type="checkbox"/> No</p>		<p>Photo #:</p>	<ul style="list-style-type: none"> Alter route
<p>Signs at Toilet Rooms</p>			
<p>3.5 Do text characters contrast with their backgrounds? [703.5]</p> <p>Are text characters raised? [703.2]</p> <p>Is there Braille? [703.3]</p> <p>Is the sign mounted: On the wall on the latch side of the door? [703.4.2]</p> <p>Note: Signs are permitted on the push side of doors with closers and without hold-open devices.</p> <p>With clear floor space beyond the arc of the door swing between the closed position and 45-degree open position, at least 18 x 18 inches centered on the tactile characters? * [703.4.2]</p> <p><input type="checkbox"/> Yes <input checked="" type="checkbox"/> No</p>	<p>Photo #:</p>	<p>Photo #:</p>	<ul style="list-style-type: none"> Install tactile sign Relocate sign <p>* If constructed before 3/15/2012 and a person may approach within 3 inches of the sign without encountering protruding objects or standing within the door swing, relocation not required</p>





<p>So the baseline of the lowest character is at least 48 inches above the floor and the baseline of the highest character is no more than 60 inches above the floor? * [703.4.1]</p> <p>Note: If the sign is at double doors with one active leaf, the sign should be on the inactive leaf; if both leaves are active, the sign should be on the wall to the right of the right leaf.</p>	<p><input type="checkbox"/> Yes <input checked="" type="checkbox"/> No</p> <p>Measurement:</p>		<p>*If constructed before 3/15/2012 and mounted no higher than 60 inches to the centerline of the sign, relocation is not required</p>
--	--	---	--

		Photo #:	
Entrance			
<p>3.6 Is the door opening width at least 32 inches clear, between the face of the door and the stop, when the door is open 90 degrees? [404.2.3]</p>	<p><input checked="" type="checkbox"/> Yes <input type="checkbox"/> No</p> <p>Measurement:</p>		<p>• Install offset hinges • Alter the doorway</p>
<p>3.7 If there is a front approach to the pull side of the door is there at least 18 inches of maneuvering clearance beyond the latch side plus 60 inches clear depth?</p> <p>Note: See 2010 Standards 404.2.4 for maneuvering clearance requirements on the push side of the door and side approaches to the pull side of the door.</p> <p>On both sides of the door, is the floor surface of the maneuvering clearance level (no steeper than 1:48)? [404.2.4]</p>	<p><input checked="" type="checkbox"/> Yes <input type="checkbox"/> No</p> <p>Measurement:</p>		<p>• Remove obstructions • Reconfigure walls • Add automatic door opener</p>

<p>3.8 If the threshold is vertical is it no more than 1/4 inch high?</p> <p>Or</p> <p>No more than 1/8 inch high with the top 1/8 inch beveled no steeper than 1:2, if the threshold was installed on or after the 1991 ADA Standards went into effect (1/26/93)?</p> <p>Or</p> <p>No more than 1/8 inch high with the top 1/8 inch beveled no steeper than 1:2, if the threshold was installed before the 1991 ADA Standards went into effect (1/26/93)? [404.2.5, 303.2]</p> <p>Note: The first 1/8 inch of the 1/8 or 1/4 inch threshold may be vertical; the rest must be beveled.</p>	<p><input type="checkbox"/> Yes <input type="checkbox"/> No</p> <p>Measurement:</p>		<p>threshold is flat</p> <p>• Remove or replace threshold</p>
<p>3.9 Is the door equipped with hardware that is operable with one hand and does not require tight grasping, pinching or twisting of the wrist?</p> <p>Door handle?</p> <p>Lock (if provided)?</p>	<p><input type="checkbox"/> Yes <input checked="" type="checkbox"/> No</p>		<p>• Replace inaccessible knob with lever, loop or push hardware • Add automatic door opener</p>

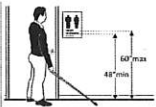
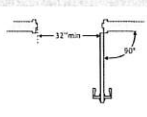
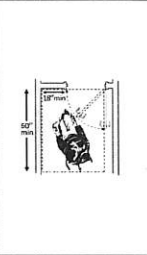
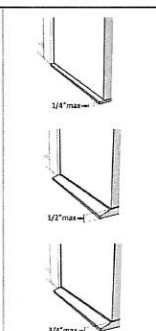
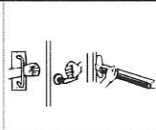
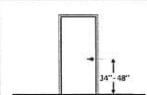
<p>[404.2.7]</p>		Photo #:	
<p>3.10 Are the operable parts of the door hardware mounted no less than 34 inches and no greater than 48 inches above the floor? [404.2.7]</p>	<p><input checked="" type="checkbox"/> Yes <input type="checkbox"/> No</p> <p>Measurement:</p>		<p>• Change hardware height</p>
<p>3.11 Can the door be opened easily (5 pounds maximum force)? [404.2.9]</p> <p>Note: You can use a pressure gauge or fish scale to measure force. If you do not have one you will need to judge whether the door is easy to open.</p>	<p><input checked="" type="checkbox"/> Yes <input type="checkbox"/> No</p> <p>Measurement:</p>		<p>• Adjust or replace closers • Install lighter doors • Install power-assisted or automatic door openers</p>
<p>3.12 If the door has a closer, does it take at least 5 seconds to close from an open position of 90 degrees to a position of 12 degrees from the latch? [404.2.8.1]</p>	<p><input type="checkbox"/> Yes <input checked="" type="checkbox"/> No</p> <p>Measurement: 3 seconds</p>		<p>• Adjust closer</p>

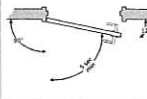
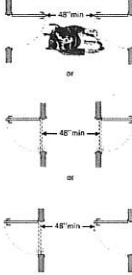
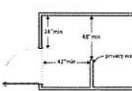
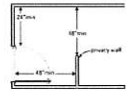

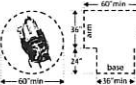
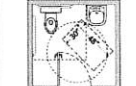
<p>3.13 If there are two doors in a series, e.g., vestibule, is the distance between the doors at least 48 inches plus the width of the doors when swinging into the space? [404.2.6]</p>	<p><input type="checkbox"/> Yes <input type="checkbox"/> No Measurement:</p>		<p>one door Photo #: • Remove inner door • Change door swing</p>
<p>3.14 If there is a privacy wall and the door swings out, is there at least 24 inches of maneuvering clearance beyond the door latch side and 42 inches to the privacy wall? [404.2.4]</p>	<p><input checked="" type="checkbox"/> Yes <input type="checkbox"/> No Measurement: 35</p>		<p>Photo #: • Reconfigure space</p>

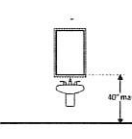
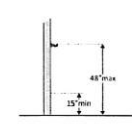
<p>3.15 If there is a privacy wall and the door swings in, is there at least 24 inches of maneuvering clearance beyond the door latch side and at least 48 inches to the privacy wall if there is no door closer or at least 54 inches if there is a door closer? [404.2.4]</p>	<p><input checked="" type="checkbox"/> Yes <input type="checkbox"/> No Measurement:</p>		<p>Photo #: • Reconfigure space</p>
In the Toilet Room			
<p>3.16 Is there a clear path to at least one of each type of fixture, e.g. lavatory, hand dryer, etc., that is at least 36 inches wide? [403.5.1]</p>	<p><input checked="" type="checkbox"/> Yes <input type="checkbox"/> No Measurement:</p>		<p>Photo #: • Remove obstructions</p>
<p>3.17 Is there clear floor space available for a person in a wheelchair to turn around, i.e. a circle at least 60 inches in diameter or a T-shaped space within a 60-inch square? [603.2.1]</p>	<p><input type="checkbox"/> Yes <input checked="" type="checkbox"/> No Measurement: 57 inches in women's</p>		<p>Photo #: • Move or remove partitions, fixtures or objects such as trash cans</p>
<p>3.18 In a single user toilet room if the door swings in and over a clear floor space at an accessible fixture, is there a clear floor space at least 30 x 48 inches beyond the swing of the door? [603.2.3 Exception 2]</p>	<p><input type="checkbox"/> Yes <input type="checkbox"/> No Measurement:</p>		<p>Photo #: • Reverse door swing • Alter toilet room</p>



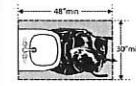
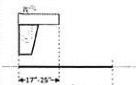
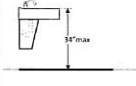
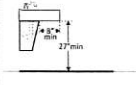

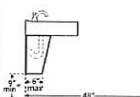
<p>3.19 If the mirror is over a lavatory or countertop, is the bottom edge of the reflecting surface no higher than 40 inches above the floor? Or If the mirror is not over the lavatory or countertop, is the bottom edge of the reflecting surface no higher than 35 inches above the floor? [603.3]</p>	<p><input type="checkbox"/> Yes <input checked="" type="checkbox"/> No Measurement: 51" <input type="checkbox"/> Yes <input checked="" type="checkbox"/> No Measurement: women's is 43 but men's is 43</p>		<p>Photo #: • If installed before 3/15/2012 and the bottom edge of the reflecting surface is no higher than 40 inches above the floor, lowering the mirror to 35 inches is not required • Lower the mirror • Add another mirror</p>
<p>3.20 If there is a coat hook, is it no less than 15 inches and no greater than 48 inches above the floor? [603.4]</p>	<p><input type="checkbox"/> Yes <input checked="" type="checkbox"/> No Measurement: 60 inches</p>		<p>Photo #: • Adjust hook • Replace with or provide additional accessible hook • If installed before 3/15/2010 and the clear floor space allows a parallel approach, the coat hook may be 54 inches above the floor.</p>

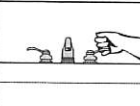
Lavatories The 2010 Standards refer to sinks in toilet rooms as lavatories.

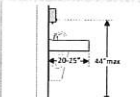
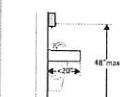
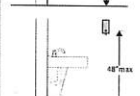
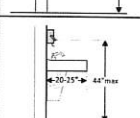
<p>3.21 Does at least one lavatory have a clear floor space for a forward approach at least 30 inches wide and 48 inches long? [606.2]</p>	<p><input checked="" type="checkbox"/> Yes <input type="checkbox"/> No Measurement:</p>		<p>Photo #: • Alter lavatory • Replace lavatory</p>
<p>3.22 Do no less than 17 inches and no greater than 25 inches of the clear floor space extend under the lavatory so that a person using a wheelchair can get close enough to reach the faucet? [306.2]</p>	<p><input checked="" type="checkbox"/> Yes <input type="checkbox"/> No Measurement: 23</p>		<p>Photo #: • Alter lavatory • Replace lavatory</p>
<p>3.23 Is the front of the lavatory or counter surface, whichever is higher, no more than 34 inches above the floor? [606.3]</p>	<p><input checked="" type="checkbox"/> Yes <input type="checkbox"/> No Measurement: 31.5</p>		<p>Photo #: • Alter lavatory • Replace lavatory</p>
<p>3.24 Is there at least 27 inches clearance from the floor to the bottom of the lavatory that extends at least 8 inches under the lavatory for knee clearance? [306.3.3]</p>	<p><input checked="" type="checkbox"/> Yes <input type="checkbox"/> No Measurement: 30</p>		<p>Photo #: • Alter lavatory • Replace lavatory</p>

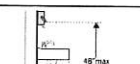
<p>3.25 Is there toe clearance at least 9 inches high? [306.3.3]</p> <p>Note: Space extending greater than 6 inches beyond the available toe clearance at 9 inches above the floor is not considered toe clearance.</p>	<p><input checked="" type="checkbox"/> Yes <input type="checkbox"/> No</p> <p>Measurement:</p>		<p>Photo #:</p> <ul style="list-style-type: none"> • Alter lavatory • Replace lavatory
<p>3.26 Are pipes below the lavatory insulated or otherwise configured to protect against contact? [606.5]</p>	<p><input type="checkbox"/> Yes <input checked="" type="checkbox"/> No</p>		<p>Photo #: 3</p> <ul style="list-style-type: none"> • Install insulation • Install cover panel
<p>3.27 Can the faucet be operated without tight grasping, pinching, or twisting of the wrist?</p> <p>Is the force required to activate the faucet no greater than 5 pounds? [606.4]</p>	<p><input type="checkbox"/> Yes <input checked="" type="checkbox"/> No</p> <p><input checked="" type="checkbox"/> Yes <input type="checkbox"/> No</p>		<p>Photo #:</p> <ul style="list-style-type: none"> • Adjust faucet • Replace faucet

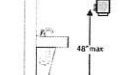
<p>Soap Dispensers and Hand Dryers (2010 Standards – 602)</p>					
<p>3.28 Are the operable parts of the soap dispenser within one of the following reach ranges:</p> <p>Above lavatories or counters no less than 20 inches and no greater than 35 inches deep; no higher than 44 inches above the floor? [308.2.2]</p>	<p><input type="checkbox"/> Yes <input checked="" type="checkbox"/> No</p> <p>Measurement: 6 inches</p>		<p>Photo #:</p>	<ul style="list-style-type: none"> • Adjust dispensers • Replace with or provide additional accessible dispensers 	
<p>Above lavatories less than 20 inches deep; no higher than 48 inches above the floor?</p>	<p><input checked="" type="checkbox"/> Yes <input type="checkbox"/> No</p> <p>Measurement:</p>		<p>Photo #:</p>		
<p>Not over an obstruction; no higher than 48 inches above the floor? [308.2]</p>	<p><input type="checkbox"/> Yes <input checked="" type="checkbox"/> No</p> <p>Measurement: 52 inches</p>		<p>Photo #:</p>		
<p>3.29 Are the operable parts of the hand dryer or towel dispenser within one of the following reach ranges:</p> <p>Above lavatories or counters no less than 20 inches and no greater than 25 inches deep; no higher than 44 inches above the floor?</p>	<p><input type="checkbox"/> Yes <input checked="" type="checkbox"/> No</p> <p>Measurement: 6 in men's</p>		<p>Photo #:</p>	<ul style="list-style-type: none"> • Adjust dispensers • Replace with or provide additional accessible dispensers 	

<p>floor?</p> <p>Above lavatories less than 20 inches deep; no higher than 48 inches above the floor?</p>	<p><input type="checkbox"/> Yes <input type="checkbox"/> No</p> <p>Measurement:</p>		<p>Photo #:</p>
<p>Not over an obstruction; no higher than 48 inches above the floor? [308.2]</p>	<p><input type="checkbox"/> Yes <input type="checkbox"/> No</p> <p>Measurement:</p>		<p>Photo #:</p>
<p>Can the operable parts of the hand dryer or towel dispenser be operated without tight grasping, pinching or twisting of the wrist?</p>	<p><input checked="" type="checkbox"/> Yes <input type="checkbox"/> No</p>		<p>Photo #:</p>
<p>Is the force required to activate the hand dryer or towel dispenser no greater than 5 pounds? [309.4]</p>	<p><input checked="" type="checkbox"/> Yes <input type="checkbox"/> No</p> <p>Measurement:</p>		<p>Photo #:</p>
<p>Water Closets in Single-User Toilet Rooms and Compartments (Stalls) The 2010 Standards refer to toilets as water closets.</p>			
<p>3.30 Is the centerline of the water closet no less than 16 inches and no greater than 18 inches from the side wall or partition? [604.2]</p>	<p><input checked="" type="checkbox"/> Yes <input type="checkbox"/> No</p> <p>Measurement: 17</p>		<p>Photo #:</p> <ul style="list-style-type: none"> • Move toilet • Replace toilet • Move partition

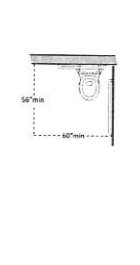
<p>3.31 Is clearance provided around the water closet measuring at least 60 inches from the side wall and at least 56 inches from the rear wall? [604.3.1]</p>	<p><input checked="" type="checkbox"/> Yes <input type="checkbox"/> No</p> <p>Measurement: side wall 53 rear 72</p>		<p>Photo #:</p> <ul style="list-style-type: none"> • If constructed before 3/15/12, clearances around water closets in single user toilet rooms can be 48 inches wide by 66 inches long or 48 inches wide by 56 inches long (depending on the approach to the water closet, see 1991 Standards Figure 28) and the lavatory may overlap that clearance if the door to the room does not swing into the required clearances at fixtures (such as lavatories, water closet and urinals) and the edge of the lavatory is at least 18 inches from the centerline of the water closet • Alter room/compartment for clearance
<p>3.32 Is the height of the water closet no less than 17 inches and no greater than 19 inches above the floor measured to the top of the seat? [604.4]</p>	<p><input checked="" type="checkbox"/> Yes <input type="checkbox"/> No</p> <p>Measurement: 18"</p>		<p>Photo #:</p> <ul style="list-style-type: none"> • Adjust toilet height • Replace toilet

<p>3.33 Is there a grab bar at least 42 inches long on the side wall? <input type="checkbox"/> Yes <input checked="" type="checkbox"/> No Measurement: 25"</p> <p>Is it located no more than 12 inches from the rear wall? <input type="checkbox"/> Yes <input checked="" type="checkbox"/> No Measurement: 18"</p> <p>Does it extend at least 54 inches from the rear wall? [604.5.1] <input type="checkbox"/> Yes <input checked="" type="checkbox"/> No Measurement: 37"</p> <p>Is it mounted no less than 33 inches and no greater than 36 inches above the floor to the top of the gripping surface? [609.4] <input checked="" type="checkbox"/> Yes <input checked="" type="checkbox"/> No Measurement: angled at a slope 28 low and 44 high</p> <p>Is there at least 12 inches clearance between the grab bar and protruding objects above? <input type="checkbox"/> Yes <input checked="" type="checkbox"/> No Measurement: in mens dispenser just a couple inches below</p> <p>Is there at least 1 1/2 inches clearance between the wall and the grab bar 1 1/2 inches? [609.3] <input type="checkbox"/> Yes <input checked="" type="checkbox"/> No Measurement: 4"</p> <p><input type="checkbox"/> Yes <input type="checkbox"/> No</p>		<p>Photo #:</p>	<ul style="list-style-type: none"> • Install grab bar • Relocate grab bar • Relocate objects <p>* If constructed before 3/15/2012 grab bars do not need to be relocated; there are no space requirements above and below grab bars in the 1991 Standards</p>
---	--	-----------------	---

<p>3.34 Is there a grab bar at least 36 inches long on the rear wall? <input type="checkbox"/> Yes <input checked="" type="checkbox"/> No Measurement:</p> <p>Does it extend at least 12 inches from the centerline of the water closet on one side (side wall)? <input type="checkbox"/> Yes <input type="checkbox"/> No Measurement:</p> <p>Does it extend at least 24 inches on the other (open) side? [604.5.2] <input type="checkbox"/> Yes <input type="checkbox"/> No Measurement:</p> <p>Is it mounted no less than 33 inches and no greater than 36 inches above the floor to the top of the gripping surface? [609.4] <input type="checkbox"/> Yes <input type="checkbox"/> No Measurement:</p> <p>Are there at least 12 inches clearance between the grab bar and protruding objects above? <input type="checkbox"/> Yes <input type="checkbox"/> No Measurement:</p> <p>Are there at least 1 1/2 inches clearance between the grab bar and projecting objects below? <input type="checkbox"/> Yes <input type="checkbox"/> No Measurement:</p> <p><input type="checkbox"/> Yes <input type="checkbox"/> No</p>		<p>Photo #:</p>	<ul style="list-style-type: none"> • Install grab bar • Relocate grab bar • Relocate objects <p>* If constructed before 3/15/2012 grab bars do not need to be relocated;</p>
--	--	-----------------	---



<p>Is the space between the wall and the grab bar 1 1/2 inches? [609.3] <input type="checkbox"/> Yes <input type="checkbox"/> No Measurement:</p> <p>Photo #:</p> <p>there are no space requirements above and below grab bars in the 1991 Standards</p>			
<p>3.35 If the flush control is hand operated, is the operable part located no higher than 48 inches above the floor? [604.6] <input checked="" type="checkbox"/> Yes <input type="checkbox"/> No Measurement:</p> <p>Photo #:</p> <p>• Move control • Install sensor with override button no higher than 48 inches</p>		<p>Photo #:</p>	
<p>3.36 If the flush control is hand operated, can it be operated with one hand and without tight grasping, pinching, or twisting of the wrist? <input checked="" type="checkbox"/> Yes <input type="checkbox"/> No</p> <p>Is the force required to activate the flush control no greater than 5 pounds? [605.4] <input checked="" type="checkbox"/> Yes <input type="checkbox"/> No Measurement:</p> <p>Photo #:</p> <p>• Change control • Adjust control</p>		<p>Photo #:</p>	
<p>3.37 Is the flush control on the open side of the water closet? [604.6] <input checked="" type="checkbox"/> Yes <input type="checkbox"/> No</p> <p>Photo #:</p> <p>• Move control</p>		<p>Photo #:</p>	

<p>3.38 Is the toilet paper dispenser located no less than 7 inches and no greater than 9 inches from the front of the water closet to the centerline of the dispenser? [604.7] <input checked="" type="checkbox"/> Yes <input type="checkbox"/> No Measurement:</p> <p>Photo #:</p> <p>* If constructed before 3/15/2012 dispenser does not need to be relocated if it is within reach from the water closet seat; the 1991 Standards do not specify distance from the front of the water closet</p> <ul style="list-style-type: none"> • Relocate dispenser 		<p>Photo #:</p>	
<p>3.39 Is the outlet of the dispenser: Located no less than 15 inches and no greater than 48 inches above the floor? <input checked="" type="checkbox"/> Yes <input type="checkbox"/> No Measurement:</p> <p>Not located behind grab bars? <input checked="" type="checkbox"/> Yes <input type="checkbox"/> No</p> <p>Photo #:</p> <ul style="list-style-type: none"> • Relocate dispenser 		<p>Photo #:</p>	
<p>3.40 Does the dispenser allow continuous paper flow? [604.7] <input checked="" type="checkbox"/> Yes <input type="checkbox"/> No</p> <p>Photo #:</p> <ul style="list-style-type: none"> • Adjust dispenser • Replace dispenser 		<p>Photo #:</p>	

Toilet Compartments (Stalls)

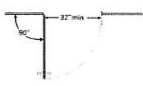
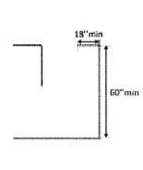

ADA Checklist for Existing Facilities

Priority 3 – Toilet Rooms

<p>3.41 Is the door opening width at least 32 inches clear, between the face of the door and the stop, when the door is open 90 degrees? [604.8.1.2]</p>	<p><input checked="" type="checkbox"/> Yes <input type="checkbox"/> No Measurement:</p>		<p>Photo #:</p> <ul style="list-style-type: none"> • Widen door width
<p>3.42 If there is a front approach to the pull side of the door, is there at least 18 inches of maneuvering clearance beyond the latch side plus 60 inches clear depth? [604.8.1.2] Note: See 2010 Standards 604.8.1.2 Doors for maneuvering clearance requirements on the push side of the door and side approaches to the pull side of the door</p>	<p><input type="checkbox"/> Yes <input type="checkbox"/> No Measurement:</p>		<p>Photo #:</p> <ul style="list-style-type: none"> • Remove obstructions
<p>3.43 Is the door self-closing? [604.8.1.2]</p>	<p><input type="checkbox"/> Yes <input checked="" type="checkbox"/> No</p>		<p>Photo #:</p> <ul style="list-style-type: none"> • Add closer • Replace door

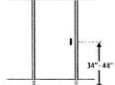

ADA Checklist for Existing Facilities

Priority 3 – Toilet Rooms

<p>3.44 Are there door pulls on both sides of the door that are operable with one hand and do not require tight grasping, pinching or twisting of the wrist? [604.8.1.2]</p>	<p><input type="checkbox"/> Yes <input checked="" type="checkbox"/> No</p>		<p>doors push easily both ways so there really isn't an correction needed. Saloon style</p>	<p>Photo #:</p> <ul style="list-style-type: none"> • If constructed before 3/15/2012 door pulls do not need to be added; door pulls are not required in the 1991 Standards • Replace hardware
<p>3.45 Is the lock operable with one hand and without tight grasping, pinching or twisting of the wrist? [309.4]</p>	<p><input type="checkbox"/> Yes <input checked="" type="checkbox"/> No</p>		<p>no locks</p>	<p>Photo #:</p> <ul style="list-style-type: none"> • Replace lock
<p>3.46 Are the operable parts of the door hardware mounted no less than 34 inches and no greater than 48 inches above the floor? [404.2.7]</p>	<p><input checked="" type="checkbox"/> Yes <input type="checkbox"/> No Measurement:</p>		<p>no operable parts</p>	<p>Photo #:</p> <ul style="list-style-type: none"> • Relocate hardware

ADA Checklist for Existing Facilities

Priority 3 – Toilet Rooms

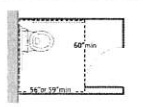
<p>3.47 Is the compartment at least 60 inches wide? [604.8.1.1]</p>	<p><input type="checkbox"/> Yes <input checked="" type="checkbox"/> No Measurement: 53 wide in womens less in mens</p>		<p>Photo #:</p> <ul style="list-style-type: none"> • Widen compartment
<p>3.48 If the water closet is wall hung, is the compartment at least 56 inches deep? [604.8.1.1]</p>	<p><input type="checkbox"/> Yes <input type="checkbox"/> No Measurement:</p>		<p>Photo #:</p> <ul style="list-style-type: none"> • not wall hung • Widen compartment
<p>3.49 If the water closet is floor mounted, is the compartment at least 59 inches deep? [604.8.1.1]</p>	<p><input checked="" type="checkbox"/> Yes <input type="checkbox"/> No Measurement: 72</p>		<p>Photo #:</p> <ul style="list-style-type: none"> • Alter compartment
<p>3.50 If the door swings in, is the minimum required compartment area provided beyond the swing of the door (60 inches x 54 inches if water closet is wall hung or 59 inches if water closet is floor mounted)? [604.8.1.1]</p>	<p><input type="checkbox"/> Yes <input type="checkbox"/> No Measurement:</p>		<p>Photo #:</p> <ul style="list-style-type: none"> • door swings both ways easily • Reverse door swing • Alter compartment

ADA Checklist for Existing Facilities

Priority 3 – Toilet Rooms

<p><input type="checkbox"/> Yes <input type="checkbox"/> No</p>	<p>Photo #:</p> <ul style="list-style-type: none"> • • •
<p><input type="checkbox"/> Yes <input type="checkbox"/> No</p>	<p>Photo #:</p> <ul style="list-style-type: none"> • • •
<p><input type="checkbox"/> Yes <input type="checkbox"/> No</p>	<p>Photo #:</p> <ul style="list-style-type: none"> • • •

ADA Checklist for Existing Facilities

Priority 4 – Additional Access

Based on the 2010 ADA Standards for Accessible Design

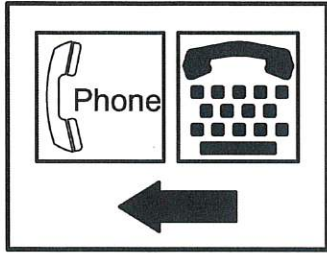

Project _____
 Building _____
 Location _____
 Date _____
 Surveyors _____
 Contact Information _____

Amenities such as drinking fountains and public telephones should be accessible to people with disabilities.



This checklist was produced by the New England ADA Center, a project of the Institute for Human Centered Design and a member of the ADA National Network. This checklist was developed under a grant from the Department of Education, MEHR grant number H133AG0092-01A. However the contents do not necessarily represent the policy of the Department of Education, and you should not assume endorsement by the Federal Government.



Questions or comments on the checklist contact the New England ADA Center at 617-695-0085 voice/tty or ADInfo@NewEnglandADA.org

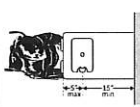

For the full set of checklists, including the checklists for recreation facilities visit www.ADAchecklist.org.



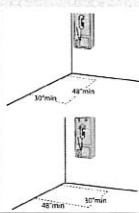

Priority 4 – Additional Access	Comments	Possible Solutions
<p>Drinking Fountains</p> <p>4.1 Does at least one drinking fountain have a clear floor space at least 30 inches wide x at least 48 inches long centered in front of it for a forward approach? [See 2010 ADA Standards for Accessible Design – 602.2]</p> <p>Measurement: <input type="checkbox"/> Yes <input type="checkbox"/> No</p> <p>Photo #:</p>	no drinking fountains	<p>*If installed before 3/15/2012, a parallel approach is permitted and the clear floor space is not required to be centered</p> <ul style="list-style-type: none"> Alter space Relocate drinking fountain Install a drinking fountain in another location
<p>4.2 If there is a forward approach, do no less than 17 inches and no greater than 25 inches of the clear floor space extend under the drinking fountain? [305.2.2, 306.2.3]</p> <p>Note: If the drinking fountain is primarily for children's use and the spout is no more than 30 inches above the floor and no more than 3 3/4 inches from the edge of the unit, a parallel approach is permitted.</p> <p>Measurement: <input type="checkbox"/> Yes <input type="checkbox"/> No</p> <p>Photo #:</p>		<ul style="list-style-type: none"> Alter space Replace drinking fountain

<p>4.3 If the drinking fountain is no deeper than 20 inches, are the operable parts no higher than 48 inches above the floor? [308.2.2]</p> <p>Measurement: <input type="checkbox"/> Yes <input type="checkbox"/> No</p> <p>Photo #:</p>		<ul style="list-style-type: none"> Adjust drinking fountain Replace drinking fountain
<p>4.4 If the drinking fountain is no less than 20 inches and no greater than 25 inches deep, are the operable parts no higher than 44 inches above the floor? [308.2.2]</p> <p>Measurement: <input type="checkbox"/> Yes <input type="checkbox"/> No</p> <p>Photo #:</p>		<ul style="list-style-type: none"> Adjust drinking fountain Replace drinking fountain
<p>4.5 Can the control be operated with one hand and without tight grasping, pinching or twisting of the wrist? Is the force required to activate the control no more than 5 pounds? [309.4]</p> <p>Measurement: <input type="checkbox"/> Yes <input type="checkbox"/> No</p> <p>Photo #:</p>		<ul style="list-style-type: none"> Change control Adjust control
<p>4.6 Is the spout outlet no higher than 36 inches above the floor? [602.4]</p> <p>Measurement: <input type="checkbox"/> Yes <input type="checkbox"/> No</p> <p>Photo #:</p>		<ul style="list-style-type: none"> Adjust drinking fountain Replace drinking fountain

<p>4.7 Is the spout: At least 15 inches from the rear of the drinking fountain? Measurement: <input type="checkbox"/> Yes <input type="checkbox"/> No</p> <p>No more than 5 inches from the front of the drinking fountain? [602.5] Measurement: <input type="checkbox"/> Yes <input type="checkbox"/> No</p>	 <p>Photo #:</p>	<ul style="list-style-type: none"> Adjust spout Replace drinking fountain
<p>4.8 If there is more than one drinking fountain, is there at least one for standing persons? [211.2] Measurement: <input type="checkbox"/> Yes <input type="checkbox"/> No</p> <p>Is the spout outlet no lower than 38 inches and no higher than 43 inches above the floor? [602.7] Measurement: <input type="checkbox"/> Yes <input type="checkbox"/> No</p>	 <p>Photo #:</p>	<ul style="list-style-type: none"> Adjust drinking fountain Install new drinking fountain for standing height
<p>4.9 If the leading (bottom) edge of the fountain is higher than 27 inches above the floor, does the front of the fountain protrude no more than 4 inches into the circulation path? [307.2] Measurement: <input type="checkbox"/> Yes <input type="checkbox"/> No</p>	 <p>Photo #:</p>	<ul style="list-style-type: none"> Adjust drinking fountain Replace drinking fountain Add tactile warning such as permanent planter or partial walls

<p>Public Telephones</p>		<p>4.10 Does at least one telephone have a clear floor space at least 30 inches wide x at least 48 inches long for a parallel or forward approach? [704.2.1] Measurement: <input type="checkbox"/> Yes <input type="checkbox"/> No</p>	 <p>Photo #:</p>	<p>no public phones</p> <ul style="list-style-type: none"> Move telephone Install new telephone for clear floor space
<p>4.11 Is the highest operable part of the telephone no higher than 48 inches above the floor? [704.2.2] Measurement: <input type="checkbox"/> Yes <input type="checkbox"/> No</p>	 <p>Photo #:</p>	<p>Photo #:</p>	<ul style="list-style-type: none"> Adjust telephone 	
<p>4.12 If the leading (bottom) edge of the telephone is higher than 27 inches above the floor, does the front of the telephone protrude no more than 4 inches into the circulation path? [307.2] Measurement: <input type="checkbox"/> Yes <input type="checkbox"/> No</p>	 <p>Photo #:</p>	<p>Photo #:</p>	<ul style="list-style-type: none"> Adjust telephone 	

<p>4.13 Does at least one telephone have a volume control? [704.3] Measurement: <input type="checkbox"/> Yes <input type="checkbox"/> No</p>	 <p>Photo #:</p>	<ul style="list-style-type: none"> Install volume control Replace telephone with one that has volume control
<p>4.14 Is the volume control identified by a pictogram of a telephone handset with radiating sound waves? [703.7.2.3] Measurement: <input type="checkbox"/> Yes <input type="checkbox"/> No</p>	 <p>Photo #:</p>	<ul style="list-style-type: none"> Add pictogram
<p>4.15 Does at least one telephone have a TTY? [217.4.3] Note: TTY's are devices that employ interactive text-based communication through the transmission of coded signals across the telephone network. They are mainly used by people who are deaf and/or cannot speak. Measurement: <input type="checkbox"/> Yes <input type="checkbox"/> No</p>	 <p>Photo #:</p>	<ul style="list-style-type: none"> Install TTY

<p>4.16 Is the touch surface of the TTY keypad at least 34 inches above the floor? [700.4.3] Note: If a seat is provided, the TTY is not required to be 34 inches minimum above the floor. Measurement: <input type="checkbox"/> Yes <input type="checkbox"/> No</p>	 <p>Photo #:</p>	<ul style="list-style-type: none"> Adjust height of TTY
<p>4.17 Is the TTY identified by the International Symbol of TTY? [703.7.2.2] Measurement: <input type="checkbox"/> Yes <input type="checkbox"/> No</p>	 <p>Photo #:</p>	<ul style="list-style-type: none"> Add symbol
<p>4.18 Do signs that provide direction to public telephones also provide direction to the TTY? [216.9.2] Measurement: <input type="checkbox"/> Yes <input type="checkbox"/> No</p>	 <p>Photo #:</p>	<ul style="list-style-type: none"> Add signs
<p>4.19 Do telephones that do not have a TTY provide direction to the TTY? [216.9.2] Measurement: <input type="checkbox"/> Yes <input type="checkbox"/> No</p>	 <p>Photo #:</p>	<ul style="list-style-type: none"> Add signs

Fire Alarm Systems					
4.20	If there are fire alarm systems, do they have both flashing lights and audible signals? [702.1]	<input type="checkbox"/> Yes <input checked="" type="checkbox"/> No		no fire alarm system in area of use by public, there is a fire alarm system in the kitchen, no flashing light or audible signals, checked twice a year.	• Install audible and visual alarms • •
		<input type="checkbox"/> Yes <input type="checkbox"/> No			• • •
		<input type="checkbox"/> Yes <input type="checkbox"/> No			• • •
		<input type="checkbox"/> Yes <input type="checkbox"/> No			• • •
		<input type="checkbox"/> Yes <input type="checkbox"/> No			• • •

EXHIBIT FOUR: Drawings/Cost



Existing Layout
Proposed Layout
Cost Estimate
Generator

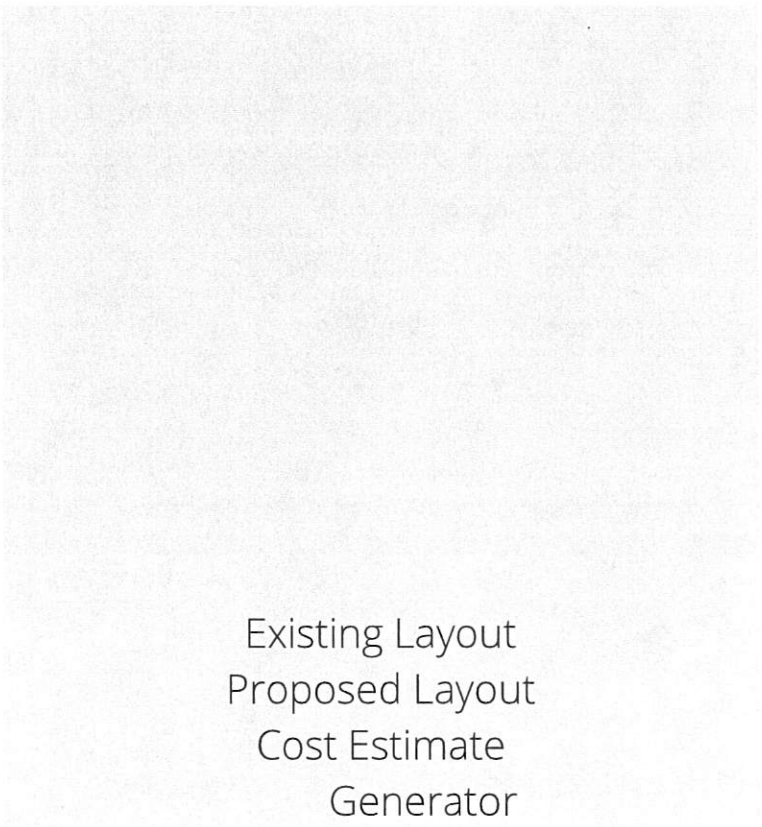
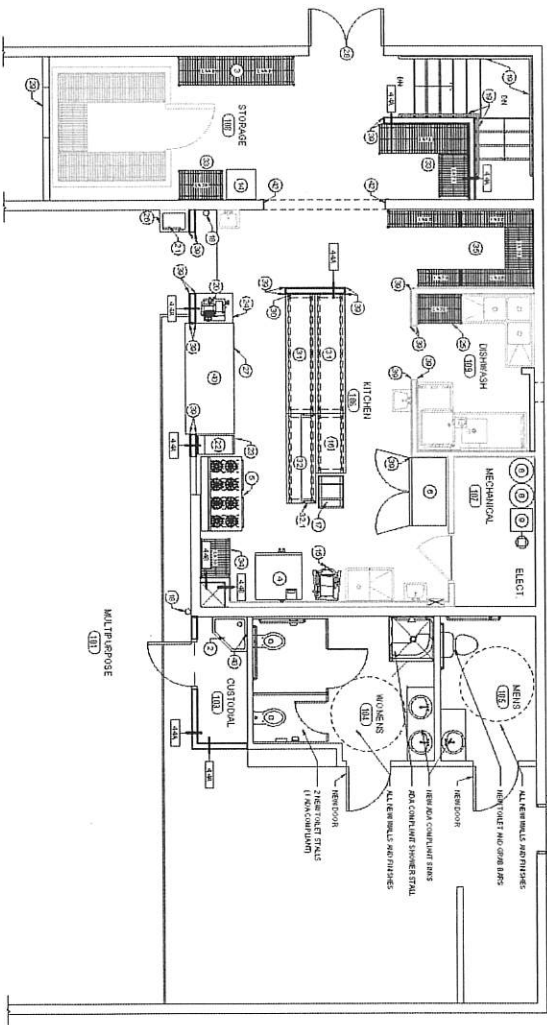
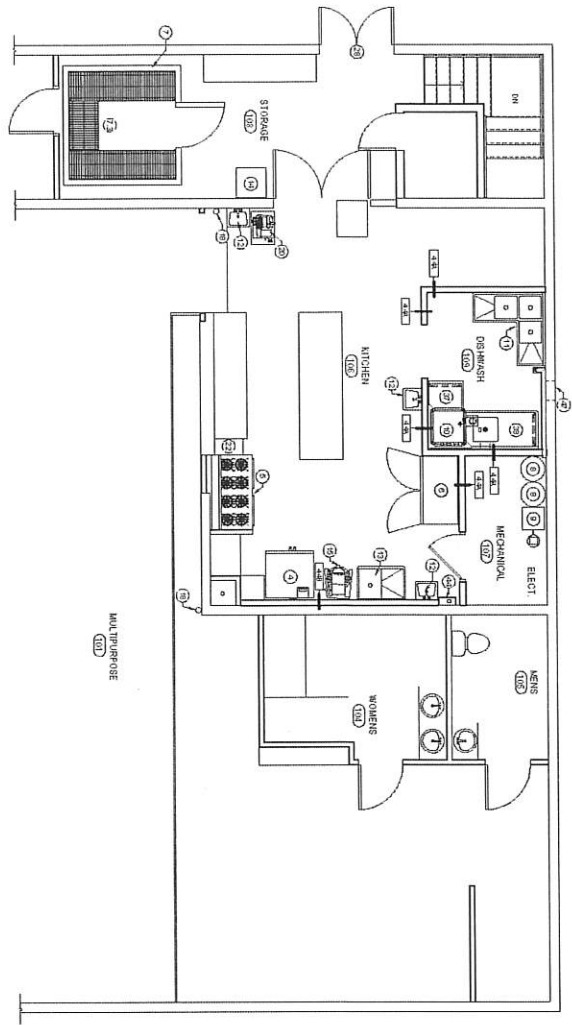

KEYNOTES

1. PROVIDE AND INSTALL COUNTER TOPS PER DRAWING AND VOUCHER SIGNATURE. PROVIDE AND INSTALL ALL PROJECT FINISH. PROVIDE AND INSTALL ALL ACCESSORIES NOT SHOWN.
2. PROVIDE AND INSTALL LIGHT FIXTURES PER DRAWING. PROVIDE AND INSTALL ALL ACCESSORIES NOT SHOWN.
3. PROVIDE AND INSTALL LIGHT FIXTURES PER DRAWING. PROVIDE AND INSTALL ALL ACCESSORIES NOT SHOWN.
4. PROVIDE AND INSTALL LIGHT FIXTURES PER DRAWING. PROVIDE AND INSTALL ALL ACCESSORIES NOT SHOWN.
5. PROVIDE AND INSTALL LIGHT FIXTURES PER DRAWING. PROVIDE AND INSTALL ALL ACCESSORIES NOT SHOWN.
6. PROVIDE AND INSTALL LIGHT FIXTURES PER DRAWING. PROVIDE AND INSTALL ALL ACCESSORIES NOT SHOWN.
7. PROVIDE AND INSTALL LIGHT FIXTURES PER DRAWING. PROVIDE AND INSTALL ALL ACCESSORIES NOT SHOWN.
8. PROVIDE AND INSTALL LIGHT FIXTURES PER DRAWING. PROVIDE AND INSTALL ALL ACCESSORIES NOT SHOWN.
9. PROVIDE AND INSTALL LIGHT FIXTURES PER DRAWING. PROVIDE AND INSTALL ALL ACCESSORIES NOT SHOWN.
10. PROVIDE AND INSTALL LIGHT FIXTURES PER DRAWING. PROVIDE AND INSTALL ALL ACCESSORIES NOT SHOWN.
11. PROVIDE AND INSTALL LIGHT FIXTURES PER DRAWING. PROVIDE AND INSTALL ALL ACCESSORIES NOT SHOWN.
12. PROVIDE AND INSTALL LIGHT FIXTURES PER DRAWING. PROVIDE AND INSTALL ALL ACCESSORIES NOT SHOWN.
13. PROVIDE AND INSTALL LIGHT FIXTURES PER DRAWING. PROVIDE AND INSTALL ALL ACCESSORIES NOT SHOWN.
14. PROVIDE AND INSTALL LIGHT FIXTURES PER DRAWING. PROVIDE AND INSTALL ALL ACCESSORIES NOT SHOWN.
15. PROVIDE AND INSTALL LIGHT FIXTURES PER DRAWING. PROVIDE AND INSTALL ALL ACCESSORIES NOT SHOWN.
16. PROVIDE AND INSTALL LIGHT FIXTURES PER DRAWING. PROVIDE AND INSTALL ALL ACCESSORIES NOT SHOWN.
17. PROVIDE AND INSTALL LIGHT FIXTURES PER DRAWING. PROVIDE AND INSTALL ALL ACCESSORIES NOT SHOWN.
18. PROVIDE AND INSTALL LIGHT FIXTURES PER DRAWING. PROVIDE AND INSTALL ALL ACCESSORIES NOT SHOWN.
19. PROVIDE AND INSTALL LIGHT FIXTURES PER DRAWING. PROVIDE AND INSTALL ALL ACCESSORIES NOT SHOWN.
20. PROVIDE AND INSTALL LIGHT FIXTURES PER DRAWING. PROVIDE AND INSTALL ALL ACCESSORIES NOT SHOWN.
21. PROVIDE AND INSTALL LIGHT FIXTURES PER DRAWING. PROVIDE AND INSTALL ALL ACCESSORIES NOT SHOWN.
22. PROVIDE AND INSTALL LIGHT FIXTURES PER DRAWING. PROVIDE AND INSTALL ALL ACCESSORIES NOT SHOWN.
23. PROVIDE AND INSTALL LIGHT FIXTURES PER DRAWING. PROVIDE AND INSTALL ALL ACCESSORIES NOT SHOWN.
24. PROVIDE AND INSTALL LIGHT FIXTURES PER DRAWING. PROVIDE AND INSTALL ALL ACCESSORIES NOT SHOWN.
25. PROVIDE AND INSTALL LIGHT FIXTURES PER DRAWING. PROVIDE AND INSTALL ALL ACCESSORIES NOT SHOWN.

KEYNOTES

26. PROVIDE AND INSTALL LIGHT FIXTURES PER DRAWING. PROVIDE AND INSTALL ALL ACCESSORIES NOT SHOWN.
27. PROVIDE AND INSTALL LIGHT FIXTURES PER DRAWING. PROVIDE AND INSTALL ALL ACCESSORIES NOT SHOWN.
28. PROVIDE AND INSTALL LIGHT FIXTURES PER DRAWING. PROVIDE AND INSTALL ALL ACCESSORIES NOT SHOWN.
29. PROVIDE AND INSTALL LIGHT FIXTURES PER DRAWING. PROVIDE AND INSTALL ALL ACCESSORIES NOT SHOWN.
30. PROVIDE AND INSTALL LIGHT FIXTURES PER DRAWING. PROVIDE AND INSTALL ALL ACCESSORIES NOT SHOWN.
31. PROVIDE AND INSTALL LIGHT FIXTURES PER DRAWING. PROVIDE AND INSTALL ALL ACCESSORIES NOT SHOWN.
32. PROVIDE AND INSTALL LIGHT FIXTURES PER DRAWING. PROVIDE AND INSTALL ALL ACCESSORIES NOT SHOWN.
33. PROVIDE AND INSTALL LIGHT FIXTURES PER DRAWING. PROVIDE AND INSTALL ALL ACCESSORIES NOT SHOWN.
34. PROVIDE AND INSTALL LIGHT FIXTURES PER DRAWING. PROVIDE AND INSTALL ALL ACCESSORIES NOT SHOWN.
35. PROVIDE AND INSTALL LIGHT FIXTURES PER DRAWING. PROVIDE AND INSTALL ALL ACCESSORIES NOT SHOWN.
36. PROVIDE AND INSTALL LIGHT FIXTURES PER DRAWING. PROVIDE AND INSTALL ALL ACCESSORIES NOT SHOWN.
37. PROVIDE AND INSTALL LIGHT FIXTURES PER DRAWING. PROVIDE AND INSTALL ALL ACCESSORIES NOT SHOWN.
38. PROVIDE AND INSTALL LIGHT FIXTURES PER DRAWING. PROVIDE AND INSTALL ALL ACCESSORIES NOT SHOWN.
39. PROVIDE AND INSTALL LIGHT FIXTURES PER DRAWING. PROVIDE AND INSTALL ALL ACCESSORIES NOT SHOWN.
40. PROVIDE AND INSTALL LIGHT FIXTURES PER DRAWING. PROVIDE AND INSTALL ALL ACCESSORIES NOT SHOWN.
41. PROVIDE AND INSTALL LIGHT FIXTURES PER DRAWING. PROVIDE AND INSTALL ALL ACCESSORIES NOT SHOWN.
42. PROVIDE AND INSTALL LIGHT FIXTURES PER DRAWING. PROVIDE AND INSTALL ALL ACCESSORIES NOT SHOWN.
43. PROVIDE AND INSTALL LIGHT FIXTURES PER DRAWING. PROVIDE AND INSTALL ALL ACCESSORIES NOT SHOWN.
44. PROVIDE AND INSTALL LIGHT FIXTURES PER DRAWING. PROVIDE AND INSTALL ALL ACCESSORIES NOT SHOWN.
45. PROVIDE AND INSTALL LIGHT FIXTURES PER DRAWING. PROVIDE AND INSTALL ALL ACCESSORIES NOT SHOWN.
46. PROVIDE AND INSTALL LIGHT FIXTURES PER DRAWING. PROVIDE AND INSTALL ALL ACCESSORIES NOT SHOWN.
47. PROVIDE AND INSTALL LIGHT FIXTURES PER DRAWING. PROVIDE AND INSTALL ALL ACCESSORIES NOT SHOWN.
48. PROVIDE AND INSTALL LIGHT FIXTURES PER DRAWING. PROVIDE AND INSTALL ALL ACCESSORIES NOT SHOWN.
49. PROVIDE AND INSTALL LIGHT FIXTURES PER DRAWING. PROVIDE AND INSTALL ALL ACCESSORIES NOT SHOWN.
50. PROVIDE AND INSTALL LIGHT FIXTURES PER DRAWING. PROVIDE AND INSTALL ALL ACCESSORIES NOT SHOWN.

PROJECT PHASING

1. DEMOLITION OF EXISTING IS TO OCCUR FIRST. DEMOLITION SHALL BE COMPLETED PRIOR TO THE START OF CONSTRUCTION OF THE NEW BUILDING.
2. THE NEW BUILDING SHALL BE CONSTRUCTED IN PHASES AS SHOWN ON THE DRAWINGS.
3. THE PHASES SHALL BE SEPARATED BY TEMPORARY WALLS TO MAINTAIN ACCESS TO THE EXISTING BUILDING.
4. THE PHASES SHALL BE SEPARATED BY TEMPORARY WALLS TO MAINTAIN ACCESS TO THE EXISTING BUILDING.
5. THE PHASES SHALL BE SEPARATED BY TEMPORARY WALLS TO MAINTAIN ACCESS TO THE EXISTING BUILDING.
6. THE PHASES SHALL BE SEPARATED BY TEMPORARY WALLS TO MAINTAIN ACCESS TO THE EXISTING BUILDING.
7. THE PHASES SHALL BE SEPARATED BY TEMPORARY WALLS TO MAINTAIN ACCESS TO THE EXISTING BUILDING.
8. THE PHASES SHALL BE SEPARATED BY TEMPORARY WALLS TO MAINTAIN ACCESS TO THE EXISTING BUILDING.

Preliminary Project Cost

Construction Costs:

1. \$80,000 for the kitchen remodel.
2. \$10,000 for the ADA upgrades including the egress door in the back.
3. \$55,000 for the toilet room renovation.
4. \$35,000 for the back-up generator.

Project Costs:

1. \$20,000 for SICOG administrative fees.
2. \$10,000 for Architectural and Engineering services.
3. \$5,000 for project contingency.



FIRST CALL JEWEL, INC.
 1410 Hollipark Drive
 IDAHO FALLS, ID 83401
 (208) 522-7777
 www.firstcalljewel.com



February 12, 2020

Dear Shelly Senior center:

Thank you for the opportunity to conduct an in-home survey and review your standby power needs in detail. At FIRST CALL JEWEL, INC., we strive to provide our customers with the best automatic standby solution, and offering Generac automatic standby generators allows us to offer the generator and transfer switch option that meets your unique requirements. As a result, we are pleased to offer you this personalized proposal.

Proposal For:

Shelly Senior center
 193 w pine st
 Shelly, ID 83274
 H: (208) 709-5826
 M: (208) 709-5826
 amanda@sicog.org

RG04524ANAX Proposal

36kW Protector Steel SCAQMD	45kw Protector Aluminum Enclosure	48kW Protector QS SCAQMD
STANDARD	RECOMMENDED	PREMIUM
		

QTY Generac items

- 1 45kw Protector Aluminum Enclosure
- 1 Generac Smart Switch, Non-service Rated, 100 amps, 120/240, 1ø, NEMA 3R
- 2 Generac Smart Switch, Non-service Rated, 200 amps, 120/240, 1ø, NEMA 3R
- 2 100 Amp Smart Management Module (SMM)

QTY Gas Materials

- 1 1" Gas Shutoff Valve

QTY Gas Pipe - Black

- 20 1" Gas Pipe
- 1" Gas Pipe

QTY Gas Regulators

- 1 Utility Gas Regulator upsize
- 1 Gas Regulator

QTY Liquid Cooled - Low kW

- 1 Annual Service
Annual Service

QTY Shop Materials

- 2 soft starter 16-33 amps
Soft starter to cut starting amps

QTY State Of Idaho Permit

- 1 Electrical Permit
- 1 Mechanical Permit

QTY Warranty

- 1 5 year limited warranty
2 Year Labor, 3 years parts, 5 year engine and alternator parts only.
- 1 Satisfaction Guarantee
If you are not satisfied with our installation and we cannot fix it to your satisfaction. We will remove our material and refund 100% of your investment anytime during the first year after the installation.

QTY Wire

- 30 SER Cable

Sub-Total:	\$23,621.43
Sales Tax:	\$0.00
Total:	\$23,621.43
Down Payment:	\$0.00
Balance Due:	\$23,621.43

EXHIBIT FIVE: Senior Center

Articles of Incorporation
Board Member Roster
Deed to Building
Project Site Map –
Explosive and Flammable Operations
Growth 2016-2019
Inspection Report
Activities
Outreach



ARTICLES OF INCORPORATION (Non-Profit)

(Instructions on back of application)

The undersigned, in order to form a Non-Profit Corporation under the provisions of Title 30, Chapter 3, Idaho Code, submits the following articles of incorporation to the Secretary of State.

2002 MAY -6 AM 10:26
SECRETARY OF STATE
STATE OF IDAHO

Article 1: The name of the corporation shall be: Shelley Area Senior Citizens, Inc.

Article 2: The purpose for which the corporation is organized is: To promote, coordinate, & integrate all aging programs in the Shelley, Idaho area. Develop & deliver social, nutritional, transportation & other services for the elderly.

Article 3: The street address of the registered office is: 193 W. Pine, Shelley, ID 83274
and the registered agent at such address is: Margo Billman, Site Director

Article 4: The board of directors shall consist of no fewer than three (3) people. The names and addresses of the initial directors are: see attached list (12 Board Members)

Article 5: The name(s) and address(es) of the incorporator(s):
Margo Billman, Site Director, P. O. Box 246, Shelley, ID 83274
Beverly Lent, Vice-Chairman, 533 Holley, Shelley, ID 83274
Marie Long, Board Secretary, 590 Holley, Shelley, ID 83274

Article 6: The mailing address of the corporation shall be:
P. O. Box 393, Shelley, ID 83274

Article 7: The corporation (does does not) have voting members.

Article 8: Upon dissolution the assets shall be distributed:
After paying or making provisions for payment of all liabilities of the corporation (some of the assets may have to be sold to do this), the Board of Directors shall dispose of such remaining assets to another organization operated for religious, charitable, literary, educational, or scientific purposes and which organization shall be exempt under Section 501 (c) (3) of the Internal Revenue Code.

Signature of all incorporators:
Margo Billman Typed Name: Margo Billman
Beverly Lent Typed Name: Beverly Lent
Marie Long Typed Name: Marie Long

Typed Name:

Typed Name:

Customer Acct #:
(if using pre-paid account)
Secretary of State use only

g:\corp\incorp forms\incorp\ncprofit.p65
Revised 01/2001

IDAHO SECRETARY OF STATE
05/07/2002 05:00
CK: 3635 CT: 160192 BH: 463971
1 @ 30.00 = 30.00 INC NONP # 2

C/43805

Shelley Senior Citizens - 2019 - 2020 Board of Directors

Name	Committee Position	Address	Home Phone	Cell Phone	Email
Jerry Byington	Programs & Activities	1077 N 1325 E, Shelley, ID 83274		201-3349	jerrybyington@gmail.com
Ross Hainsworth	Maintenance	1035 Franklin #10, Firth, ID 83236		520-5990	N/A
Evalyn Adams	Vice, Programs & Activities	924 E 1400 N, Shelley, ID 83274	357-5506	521-5506	evalynadams@gmail.com
Linda Beal	Secretary, Finance & Fundraising	372 S Park, Shelley, ID 83274		589-0559	beal.linda1@gmail.com
Ron Harada	Chairman of the Board	755 Saturn Ave, Idaho Falls, 83402		569-2330	ronharada@gmail.com
Nancy Howard	Finance & Fundraising	381 Napa Dr., Idaho Falls, ID 83404		403-2816	howardni2252@gmail.com
Barbara Steele	Finance & Fundraising	3741 Citrus Dr, Idaho Falls, ID 83404		521-6152	nickenz40@gmail.com
Verle Kotter	Maintenance	P.O. Box 103, Basalt, ID 83218	346-6652		kottsvq@juno.com
Patricia Morris	Programs & Activities	144 S Holmes, Shelley, ID 83274	357-3345		flufie13@yahoo.com
Doris Nuttall	Finance & Fundraising	740 E 1550 N, Shelley, ID 83274	357-7781		N/A
Phyllis Scheffler	Programs & Activities	5371 Free Ave, Iona, ID 83427		520-8699	phyllisscheffler7@gmail.com
Judy Thomas	Finance & Fundraising	1949 Ririe Circle, Idaho Falls, ID 83404	535-9976	569-3306	juddthomas75@tcloud.com

Instrument # 711397

BINGHAM COUNTY

10-18-2019 09:59:08 AM No. of Pages: 1

Recorded for : COMMISSIONERS

PAMELA W. ECKHARDT

Fee: 0.00

Ex-Officio Recorder Deputy

W

QUIT CLAIM DEED

Grantor, **COUNTY OF BINGHAM, STATE OF IDAHO**, with principal offices at 501 North Maple, Blackfoot, County of Bingham, State of Idaho, for good and valuable consideration, the receipt of which hereby is acknowledged, does hereby REMISE, RELEASE and forever QUITCLAIM unto the Grantee, **the CITY OF SHELLEY, STATE OF IDAHO**, with an address at 101 S Emerson Ave, Shelley, Bingham County, Idaho, 83274 and to Grantee's heirs and assigns, the following described real estate situated in Bingham County, Idaho, to wit:

Lots 22, 23, and 24 in the re-plat of lots 4 and 19 of the re-plat of block 19 of the city of Shelley, Bingham County, Idaho, according to the recorded plat thereof.

TO HAVE AND TO HOLD the said premises, with their appurtenances unto the said Grantee, their heirs and assigns so long as the property is used for the Shelley Senior Center, which is, and has been, the historical use of the property. At any time if the property is no longer used for the Shelley Senior Center then the property shall revert ownership to the Grantor. Only updated structures consistent with the Shelley Senior Center shall be deemed appropriate to be built on the property, with no other structures allowed. The covenants agreed to and the terms, conditions, and restrictions imposed as aforesaid shall be binding upon Grantees, their survivors, agents, personal representatives, heirs, assigns and all other successors to them in interest, and shall continue as a servitude running in perpetuity with the Property.

Dated:

Oct. 18, 2019

Whitney Manwaring
Whitney Manwaring, Commission Chair
Bingham County Commissioners

STATE OF IDAHO, COUNTY OF BINGHAM
On this 18th day of October, 2019,
Before me, a notary public in and for the State of Idaho,
personally Appeared Whitney Manwaring, known to me to be
the Chairman of the Bingham County Commissioners who
proved to me on the basis of satisfactory evidence to be the
person whose name is subscribed to the within instrument and
acknowledged to me that he executed the same in his
authorized capacity, and that by his signature on the instrument
the person, or the entity upon behalf of which the person acted,
executed the instrument

Caren Hawkes

Notary Public for Idaho
Residing at Blackfoot, Idaho
My Commission expires Jan. 14 2025



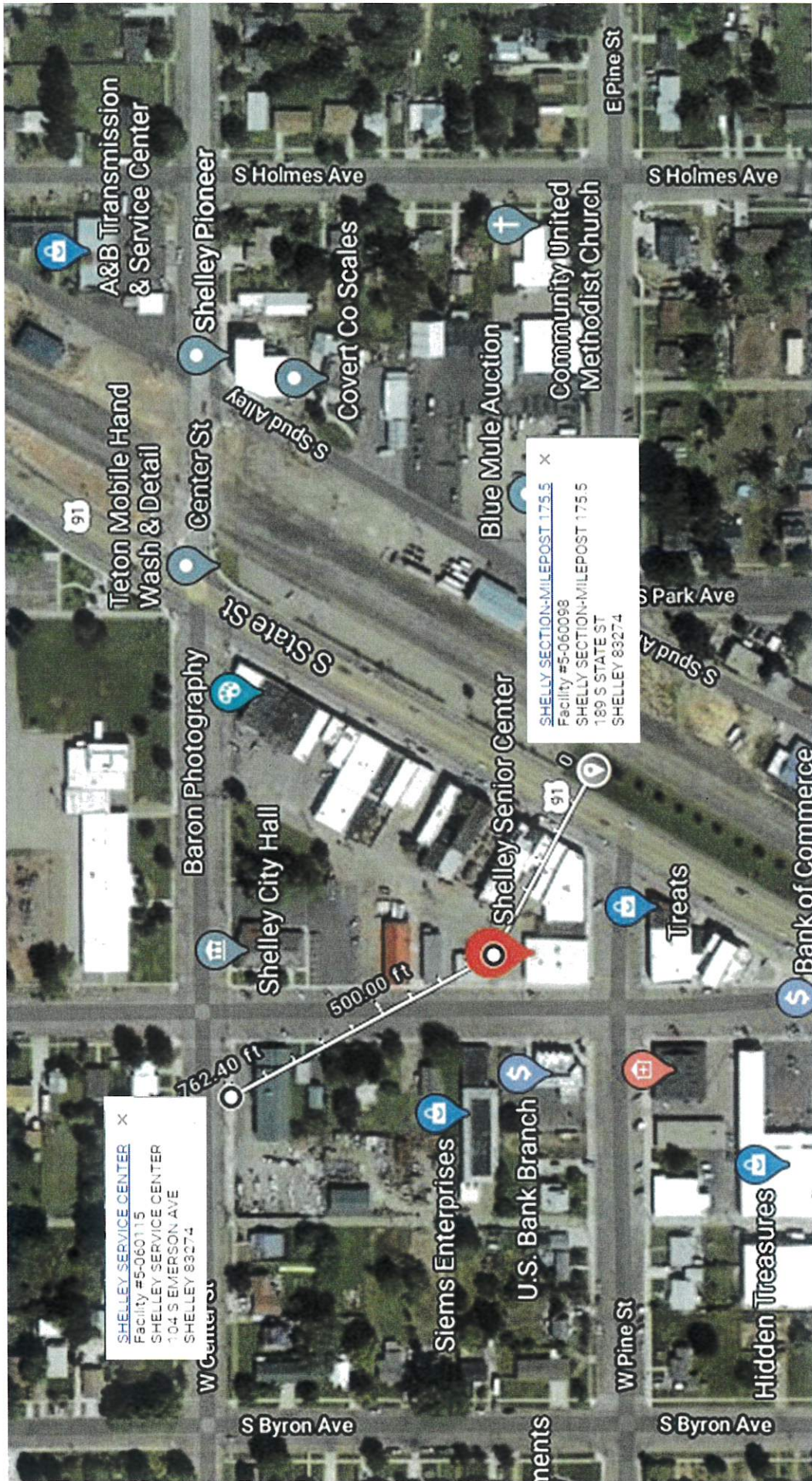

SHELLEY SERVICE CENTER X
Facility #5-060115
SHELLEY SERVICE CENTER
104 S EMERSON AVE
SHELLEY 83274

SHELLEY SECTION-MILEPOST 175.5 X
Facility #5-060098
SHELLEY SECTION-MILEPOST 175.5
189 S STATE ST
SHELLEY 83274

Growth of Meal Service at Shelley Area Senior Citizens, Inc.

	2016	2017	2018	2019	2020
Congregate					
January	353	292	629	459	370
February	380	458	617	429	
March	513	567	643	398	
April	481	519	590	370	
May	498	562	643	572	
June	507	526	572	572	
July	444	496	387	530	
August	504	550	578	570	
September	495	553	546	490	
October	484	629	607	611	
November	538	624	477	510	
December	398	509	393	429	
Total Yr	5595	6285	6682	5940	370

	2016	2017	2018	2019	2020
Home Delivered					
January	203	309	419	371	467
February	226	318	405	363	
March	262	402	509	551	
April	284	304	562	339	
May	253	374	509	402	
June	273	421	477	409	
July	264	365	375	287	
August	276	413	522	360	
September	313	412	437	322	
October	294	337	482	550	
November	317	344	422	432	
December	341	429	469	305	
Total Yr.	3306	4428	5588	4691	467.0

	2016	2017	2018	2019	2020
Total Meals	8901	10713	12328	10631	837



609

Establishment Name <i>Shelley Sr. Citizen Center</i>	License/Permit #	Number of Risk Factor Violations <i>0</i>	Number of GRP Violations <i>0</i>
Address <i>Shelley ID</i>		Number of Repeat Risk Factor Violations <i>0</i>	Number of Repeat GRP Violations <i>0</i>
City/Zip/County		TOTAL SCORE <i>0</i>	TOTAL SCORE <i>0</i>
Type: Regular <input checked="" type="checkbox"/> Preopening <input type="checkbox"/> Epidemiology <input type="checkbox"/> HACCP <input type="checkbox"/>	<input type="checkbox"/> Follow-up Report (VCR) Date: _____ <input type="checkbox"/> Follow-up Inspection Date: _____ <input type="checkbox"/> Enforcement Date: _____		A score greater than 3 Risk Factor and/or 8 GRP Med OR a score greater than 5 Risk Factor and/or 8 GRP High = Mandatory re-inspection Risk Category: L M H
Follow-up <input type="checkbox"/> Enforcement <input type="checkbox"/> Investigation <input type="checkbox"/>	Inspection Time Min: <i>30</i>	Travel Time Min: <i>30</i>	EHS: <i>53</i> Date: <i>4-29-19</i>

FOODBORNE ILLNESS RISK FACTORS AND PUBLIC HEALTH INTERVENTIONS

Compliance Status		COS		R	
Supervision (2-102)					
<input checked="" type="radio"/> IN	<input type="radio"/> OUT	Person in charge present, demonstrates knowledge, and performs duties			
<input checked="" type="radio"/> IN	<input type="radio"/> OUT	Identified Food Protection Manager			
Employee Health (2-201, 2-501)					
<input checked="" type="radio"/> IN	<input type="radio"/> OUT	Management, food employee and conditional employee; knowledge, responsibilities and reporting			
<input checked="" type="radio"/> IN	<input type="radio"/> OUT	Proper use of restriction and exclusion			
<input checked="" type="radio"/> IN	<input type="radio"/> OUT	Procedures for responding to vomiting and diarrheal event			
Good Hygienic Practices (2-401)					
<input checked="" type="radio"/> IN	<input type="radio"/> OUT	Proper eating, tasting, drinking, or tobacco use (2-401.11)			
<input checked="" type="radio"/> IN	<input type="radio"/> OUT	No discharge from eyes, nose, and mouth 2-401			
Preventing Contamination by Hands (2-301, 3-301)					
<input checked="" type="radio"/> IN	<input type="radio"/> OUT	Hands clean & properly washed (2-301)			
<input checked="" type="radio"/> IN	<input type="radio"/> OUT	No bare hand contact with Ready-To-Eat (RTE) food or a pre-approved alternative procedure properly allowed			
<input checked="" type="radio"/> IN	<input type="radio"/> OUT	Adequate handwashing sinks properly supplied and accessible			
Approved Source (3-201, 3-202)					
<input checked="" type="radio"/> IN	<input type="radio"/> OUT	Food obtained from approved source			
<input checked="" type="radio"/> IN	<input type="radio"/> OUT	Food received at proper temperature			
<input checked="" type="radio"/> IN	<input type="radio"/> OUT	Food in good condition, safe, & unadulterated			
<input checked="" type="radio"/> IN	<input type="radio"/> OUT	Required records available: shellstock tags, parasite destruction			
Protection from Contamination (3-302, 4)					
<input checked="" type="radio"/> IN	<input type="radio"/> OUT	Food separated and protected			
<input checked="" type="radio"/> IN	<input type="radio"/> OUT	Food-contact surfaces; cleaned & sanitized			

Compliance Status		COS		R	
<input checked="" type="radio"/> IN	<input type="radio"/> OUT	Proper disposition of returned, previously served, reconditioned & unsafe food			
Time/Temperature Control for Safety (3-401, 4-301)					
<input checked="" type="radio"/> IN	<input type="radio"/> OUT	Proper cooking time & temperatures			
<input checked="" type="radio"/> IN	<input type="radio"/> OUT	Proper reheating procedures for hot holding			
<input checked="" type="radio"/> IN	<input type="radio"/> OUT	Proper cooling time and temperature			
<input checked="" type="radio"/> IN	<input type="radio"/> OUT	Proper hot holding temperatures			
<input checked="" type="radio"/> IN	<input type="radio"/> OUT	Proper cold holding temperatures			
<input checked="" type="radio"/> IN	<input type="radio"/> OUT	Proper date marking and disposition			
<input checked="" type="radio"/> IN	<input type="radio"/> OUT	Time as a Public Health Control; procedures & records			
Consumer Advisory (3-603)					
<input checked="" type="radio"/> IN	<input type="radio"/> OUT	Consumer advisory provided for raw/undercooked food			
Highly Susceptible Populations (3-801)					
<input checked="" type="radio"/> IN	<input type="radio"/> OUT	Pasteurized foods used; prohibited foods not offered			
Food/Color Additives and Toxic Substances (3-302)					
<input checked="" type="radio"/> IN	<input type="radio"/> OUT	Food additives: approved & properly used			
<input checked="" type="radio"/> IN	<input type="radio"/> OUT	Toxic substances properly identified, stored, & used			
Conformance with Approved Procedures (3-502)					
<input checked="" type="radio"/> IN	<input type="radio"/> OUT	Compliance with variance/specialized process/HACCP			

Risk factors are important practices or procedures identified as the most prevalent contributing factors of foodborne illness or injury. Public health interventions are control measures to prevent foodborne illness or injury.

OBSERVATIONS AND CORRECTIVE ACTIONS

P	Pf	C	Violations cited in this report must be corrected within the time frames below, or as stated in sections 8-405.11 of the food code.	Correction Date:
			* Get more T-sticks 160°F	
			* Get more test strips	
			* Put copy of Certificate in Kitchen	
			* Three comp sink needs Rinse + Sani bins need to be air gapped.	
			* Hot pressure gauge needs to be visible off of dishwasher.	

Person in Charge (Signature) <i>Denine Wong</i>	Date
Inspector (Signature) <i>Carol Stoy</i>	Date <i>4-29-19</i>

208-221-3413

Senior/Community Center Activities

Activity	Existing Activity (insert: √)	Proposed Activity (insert: √)	No. of Days Offered Per Month or Year*	Facilitated By
Health				
Nutrition Education	√		Twice a mo.	Shelley Area Senior Citizens, Inc
Blood Pressure Checks	√		Twice a mo.	Shelley Area Senior Citizens, Inc
Fit & Fall Proof Exercise	√		8 times a mo.	S.E. Idaho Public Health
Foot Clinic	√		Once a month	Blackfoot Home Health
Health Fair	√		Once a year	Bingham Memorial Hospital
Recreation				
Pinochle	√		4 times a mo.	Shelley Area Senior Citizens, Inc
Bingo	√		4 times a mo.	Shelley Area Senior Citizens, Inc
Craft Days	√		5 days a year	Shelley Area Senior Citizens, Inc
Technology Workshops	√		5 days a year	Shelley Area Senior Citizens, Inc
Transportation	√		4 times a mo.	Shelley Area Senior Citizens, Inc
Group Trips	√			
Drawing Class	√		4 times a mo.	
Christmas Concert	√		Once a year	
Meals (home delivery/@Center)				
Home Delivered	√		103 times a yr	Shelley Area Senior Citizens, Inc
Congregate	√		103 times a yr	Shelley Area Senior Citizens, Inc
Other				
Trivia	√		4 times a mo.	Shelley Area Senior Citizens, Inc
Book Club	√		2 times a mo.	Shelley Area Senior Citizens, Inc
Clothing Exchange	√			Shelley Area Senior Citizens, Inc
Spud Days Event	√		3 days a year	Shelley Area Senior Citizens, Inc
Live Entertainment	√		2 times a mo.	Various Artists/SA Senior Cit. Inc
Spaghetti Fundraiser	√		Once a year	Shelley Area Senior Citizens, Inc
Totals				
This facility is open to the seniors/community <u>200</u> days per year				

* A service/activity that is offered 6 times per year = .5 days per month

EXHIBIT SIX: Match

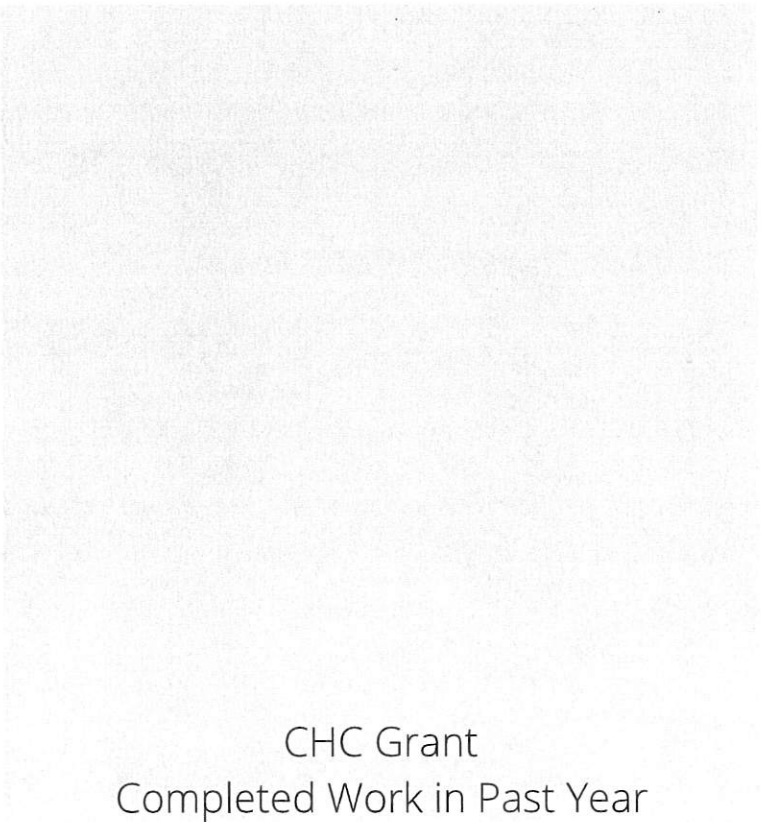



November 1, 2019

P.O Box 1644 (208) 522-2368
Idaho Falls, ID 83403 Fax (208) 529-2404
www.chcfoundation.net

Denine Wong & Ron Harada
Shelley Area Senior Citizens, Inc.
PO Box 393
Shelley, Idaho 83274

Re: CHC Foundation Grant #FALL 2019 -24 (your grant number for all correspondence)

Dear Ms. Wong and Mr. Harada,

CHC Foundation, Inc. is pleased to award **up \$15,000 to fund the first four points of Phase One of your remodel project** as stated in your grant proposal.

If applicable, this grant award is contingent upon your securing any remaining funds that you indicated would be needed to complete the total project- whether it be through bank financing, block grants, or any other means that you referred to in your budget sheet. Grant funds may be used ONLY for the purposes described in your application subject to conditions, if any, contained in this award letter. Use for unanticipated needs will be permitted ONLY by pre-approval through CHCF.

CHCF reimburses your organization's purchases. Reimbursement is ONLY for those items detailed in your grant request. Reimbursement checks are written to your organization after detailed accounts are submitted. (Copy form attached) Thus please forward copies of **paid** invoices and **cancelled** checks (front and back) of your payment of bills as they become available using the form attached.

IMPORTANT use the attached format (copy form if submitting more than one request for reimbursement). The grant funds will be sent to you upon receipt of correct documentation. If other arrangements for payment by CHCF are needed, please contact the office at (208) 522-2368. This grant award is subject to audit.

General terms and conditions of the grant are attached in addition to the reimbursement submittal form. These must be signed and returned to CHCF. Please have this letter signed by a duly authorized representative of your organization where indicated on page two. ***Make a copy for your file and return the entire original signed letter and signed general terms to CHC Foundation's address. Keep the form for submission reimbursements***

It is a pleasure to assist your organization with this grant.

Sincerely,

Scott Lee, President

Dick Fowler, Treasurer

Grantee agrees to the terms and conditions of the grant as recited in the attachment to this letter. Sign & return by Friday, November 15, 2019.

***NOTE: Monies cannot be reimbursed until this letter is signed and returned!**

Signed by: 

Title: Board Chairman

Organization's name: Shelley Area Services, Inc. City: Shelton, CT

Your grant number as assigned on page 1 of this letter: FALL 2019-24 (please write in)

Today's date: 11/7/19

--



MAINTENANCE PLUMBING
& HEATING, INC.
Marvin, Brett & Mike
P.O. Box 484 342 S. State St.
SHELLEY, IDAHO 83274
Phone (208) 357-3489

Job No. 31412

31412

Customer's Order NO.		Phone	Mechanic	Helper	Date of Order 9-12-19	Starting Date
Bill To		Shelley Sr Citizen Center			Order Taken By	
Address		193 W. Pine			<input type="checkbox"/> DAY WORK	
City		Shelley Id 83274			<input type="checkbox"/> CONTRACT	
Job Name and Location					<input type="checkbox"/> EXTRA	
				Job Phone		

Description of Work

JACKHAMMER FLOOR & REPLACE
Broken C-1. 90 IN DRAIN LINE

PARTS & LABOR 427.20

	TOTAL MATERIALS		
	TOTAL LABOR		
	TAX		
DATE COMPLETED	WORK ORDERED BY	TOTAL AMOUNT	427 20

No one home

Total amount due for above work: or

Total billing to be mailed after completion of work

Signature _____

I hereby acknowledge the satisfactory completion of the above described work.

ES

KING GEORGE'S ROYAL FLUSH

WHEN IT WON'T FLUSH CALL US

P.O. BOX 3809

IDAHO FALLS, ID 83403

DATE 5/18/19

208-528-2938

INVOICE # N^o 14421

RESPONSIBLE PARTY Shelley Service Center

CHECK # _____

SERVICE ADDRESS 193 W. Pine, Shelley

BILLING ADDRESS _____

PHONE # 208-357-3671

\$ 224.00
TOTAL

PLEASE INDICATE INVOICE # ON CHECK

TERMS: Bill out

PLEASE DETACH AND RETURN WITH YOUR REMITTANCE

DATE	DESCRIPTION			CHARGE
------	-------------	--	--	--------

	Cabled 4" main			
	from Cleanout. Ran			224
	Water & Flow tested.			
	⚡ Suggest Video inspection ⚡			

Thank You

CREDIT CARD INFO _____

SIGNATURE Diane L. Woyars



Sermon Service and Electric
 P.O. Box 1692
 Idaho Falls, ID 83403
 208-542-4545
www.sermonid.com

INVOICE

Date: Nov 27, 2019
Reason for Call: 3023-19/Preventative Maintenance
Work Order #: 3023-19
Assigned To: Wyatt Greenhalgh
Status: completed

MARGO - SHELLEY SENIOR CENTER
 193 W PINE STREET
 SHELLEY, ID 83274
 208-357-3621
seniors3621@yahoo.com

Repairs:

Travel	\$125.00
Preventative maintenance	\$336.26

Sign Here

Subtotal \$461.26
Total \$461.26

\$ 461.26

Notes:

Changed filters, cleaned flame sensors, looked at condition of coils, checked fans, and checked flames on the two roof top units on top of the building. After turning systems back on, we got the east RTU to fire and was drawing .6 amps on the inducer and 6.4 amps on the blower and everything seems to be running great. The west RTU was not wanting to fire and not showing any indications of voltage on control boards. Traced wires and found voltage coming into the unit, passed the transformer, and then to the control board but not going through allowing system to run. Talked to manager on site, she had these units put in around March this year. She called company who installed units, and they will be coming out for warranty to try and find out the issue.

Thank you



Sermon Service and Electric
 P.O. Box 1692
 Idaho Falls, ID 83403
 208-542-4545
www.sermonid.com

INVOICE

Date: Nov 26, 2019
Reason for Call: 3014-19/tstat blank-assess for PM
Work Order #: 3014-19
Assigned To: Wyatt Greenhalgh
Status: completed

MARGO - SHELLEY SENIOR CENTER
 193 W PINE STREET
 SHELLEY, ID 83274
 208-357-3621
 seniors3621@yahoo.com

Repairs:

Service Call Fee (10 to 20 Miles)	\$125.00
------------------------------------	----------

Customer Signature

Subtotal \$125.00

Total \$125.00

Notes:

Thermostat was displaying anything and after removing back of thermostat and replaced the batteries. After replacing the batteries, the display was lighting up and working properly. Manager said he would set up the programming. We will be getting pictures and material list to do the preventative maintenance on the new equipment in the future.

Thank you

EXHIBIT SEVEN: Financial

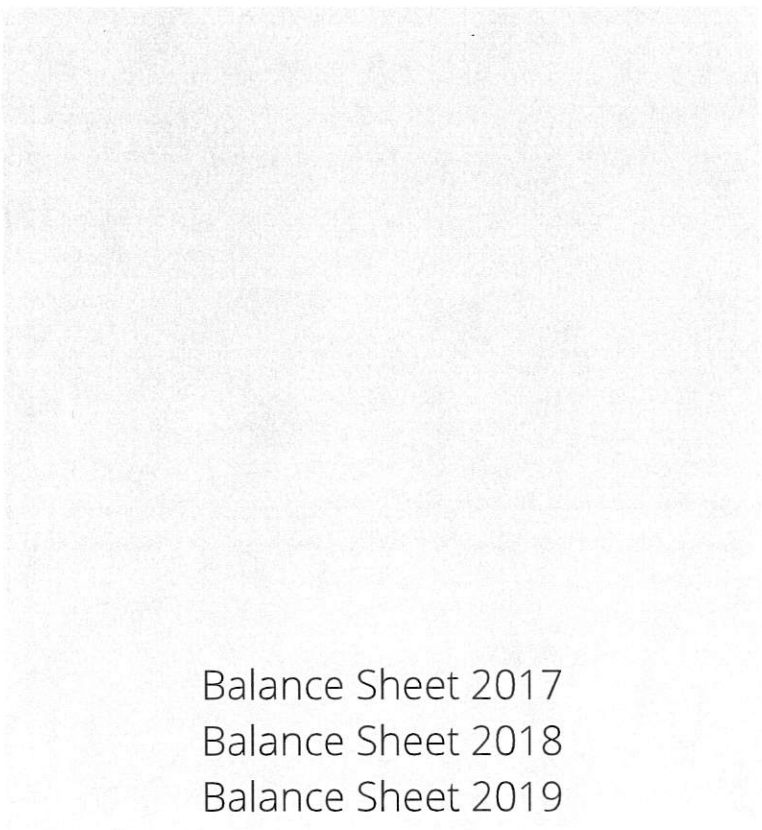

Balance Sheet 2017

Balance Sheet 2018

Balance Sheet 2019

Shelley Area Senior Citizens, Inc.
Profit & Loss
January through December 2017

	<u>Jan - Dec 17</u>
Ordinary Income/Expense	
Income	
A. Congregate - Revenue	
Title	18,700.43
USDA	6,439.63
A. Congregate - Revenue - Other	<u>27,714.26</u>
Total A. Congregate - Revenue	52,854.32
B. Home Delivery - Revenue	
Title	16,089.07
B. Home Delivery - Revenue - Other	<u>13,280.00</u>
Total B. Home Delivery - Revenue	29,369.07
C. Outreach - Revenue	
General/Doctor Trips	<u>978.55</u>
Total C. Outreach - Revenue	978.55
D. General - Revenue	
City/County	30,000.00
Donations	
\$5-20 Dollar A Month Donations	3,621.59
United Way	
Donor pledges received	61.99
Grants- UW	<u>6,621.83</u>
Total United Way	6,683.82
Donations - Other	<u>5,419.00</u>
Total Donations	15,724.41
Fund Raiser	
Bakery	2,637.25
Building Rental	440.50
Chuck-A-Rama Cards	94.00
Crafts	246.31
Pancake Breakfast	1,062.25
Pop Sales	166.00
Fund Raiser - Other	<u>5,397.94</u>
Total Fund Raiser	10,044.25
General	
Catered Meal Income	130.00
Medicaid Meal Income	1,077.38
Misc Income	201.00
Unrealized gain/loss	<u>6,688.09</u>
Total General	8,096.47
D. General - Revenue - Other	<u>3,623.28</u>
Total D. General - Revenue	<u>67,488.41</u>

Shelley Area Senior Citizens, Inc.
Profit & Loss
January through December 2017

	<u>Jan - Dec 17</u>
Total Income	150,690.35
Expense	
A. Congregate	
Custodian	4,074.00
Insurance	921.20
Miscellaneous	
Advertising/Newsletter	724.26
Laundry	278.25
Misc.	112.91
Training	14.00
Total Miscellaneous	1,129.42
New Equipment	2,642.01
Raw Food	16,581.03
Repairs	1,439.77
Supplies	
Office	846.23
Supplies - Other	1,890.27
Total Supplies	2,736.50
Utilities	4,611.16
Worker's Comp	853.30
Total A. Congregate	34,988.39
B. Home Delivery	
Insurance	296.10
Mileage	2,826.79
Miscellaneous	
Advertising/Newsletter	208.28
Laundry	79.50
Misc.	25.00
Training	6.00
Total Miscellaneous	318.78
New Equipment	527.20
Raw Food	10,433.76
Repairs	521.29
Supplies	
Office	551.89
Supplies - Other	1,030.34
Total Supplies	1,582.23
Utilities	1,152.81
Worker's Comp	289.80

Shelley Area Senior Citizens, Inc.
Profit & Loss
January through December 2017

	<u>Jan - Dec 17</u>
Total B. Home Delivery	17,948.76
C. Outreach	
Bus Maint., Insurance, Expenses	975.88
Gas & Oil	263.57
Worker's Comp.	144.90
C. Outreach - Other	1.42
Total C. Outreach	1,385.77
D. General	
Bus Maintenance, Insurance Exp.	357.61
Custodian	1,746.00
Fund Raiser	
Bakery	70.03
General	496.12
Pancake Breakfast	458.93
Pop	153.65
Fund Raiser - Other	1,812.50
Total Fund Raiser	2,991.23
Gas and Oil	107.64
Insurance	427.70
Miscellaneous	
Advertising/Newsletter	967.16
Bingo	80.70
Contract labor	135.00
Donations	26.00
Laundry	39.75
Misc.	787.81
Professional Services	830.00
Sales Tax	385.31
Miscellaneous - Other	505.62
Total Miscellaneous	3,757.35
New Equipment	1,053.06
Raw Food	1,762.31
Repairs	521.29
Supplies	
Office	441.52
Supplies - Other	946.87
Total Supplies	1,388.39
Utilities	2,470.30
Worker's Comp	322.00
Total D. General	16,904.88
E. Payroll Expenses	
Holiday	818.27
Hourly	38,272.45

4:11 PM
02/19/20
Cash Basis

Shelley Area Senior Citizens, Inc.
Profit & Loss
January through December 2017

	<u>Jan - Dec 17</u>
Officer Salary	17,431.78
Sick Pay	169.63
Taxes	
Medicare	840.44
Social Security	3,593.60
Total Taxes	4,434.04
Vacation	1,269.10
E. Payroll Expenses - Other	81.00
Total E. Payroll Expenses	62,476.27
Total Expense	133,704.07
Net Ordinary Income	16,986.28
Other Income/Expense	
Other Income	
Interest Income	1.11
Total Other Income	1.11
Net Other Income	1.11
Net Income	<u><u>16,987.39</u></u>

Shelley Area Senior Citizens, Inc.
Profit & Loss
January through December 2018

	<u>Jan - Dec 18</u>
Ordinary Income/Expense	
Income	
A. Congregate - Revenue	
Title	19,848.00
USDA	6,129.01
A. Congregate - Revenue - Other	<u>28,026.78</u>
Total A. Congregate - Revenue	54,003.79
B. Home Delivery - Revenue	
Title	20,280.00
B. Home Delivery - Revenue - Other	<u>15,995.49</u>
Total B. Home Delivery - Revenue	36,275.49
C. Outreach - Revenue	
General/Doctor Trips	<u>946.00</u>
Total C. Outreach - Revenue	946.00
D. General - Revenue	
City/County	44,900.00
Donations	
\$5-20 Dollar A Month Donations	3,540.34
United Way	
Donor pledges received	1,114.76
Grants- UW	<u>5,839.62</u>
Total United Way	6,954.38
Donations - Other	<u>6,772.00</u>
Total Donations	17,266.72
Fund Raiser	
Bakery	1,677.00
Building Rental	1,234.00
Chuck-A-Rama Cards	170.00
Crafts	171.00
Pancake Breakfast	956.00
Pop Sales	387.50
Fund Raiser - Other	<u>2,966.17</u>
Total Fund Raiser	7,561.67
General	
Catered Meal Income	1,189.00
Medicaid Meal Income	507.31
Misc Income	100.00
Unrealized gain/loss	<u>-20.15</u>
Total General	1,776.16
D. General - Revenue - Other	<u>4,940.92</u>
Total D. General - Revenue	<u>76,445.47</u>

Shelley Area Senior Citizens, Inc.
Profit & Loss
 January through December 2018

	Jan - Dec 18
Total Income	167,670.75
Expense	
A. Congregate	
Custodian	3,780.00
Insurance	258.16
Miscellaneous	
Advertising/Newsletter	1,080.81
Laundry	278.25
Misc.	133.00
Training	223.44
	1,715.50
Total Miscellaneous	1,715.50
New Equipment	3,897.92
Raw Food	18,232.38
Repairs	3,179.83
Supplies	
Office	457.52
Supplies - Other	978.46
	1,435.98
Total Supplies	1,435.98
Utilities	4,765.12
Worker's Comp	1,089.68
	38,354.57
Total A. Congregate	38,354.57
B. Home Delivery	
Insurance	82.98
Mileage	3,532.47
Miscellaneous	
Advertising/Newsletter	356.14
Laundry	79.50
Misc.	38.00
Training	101.82
	575.46
Total Miscellaneous	575.46
New Equipment	1,527.01
Raw Food	13,622.73
Repairs	1,184.22
Supplies	
Office	434.12
Supplies - Other	1,916.16
	2,350.28
Total Supplies	2,350.28
Utilities	1,228.21
Worker's Comp	370.08
	370.08

Shelley Area Senior Citizens, Inc.
Profit & Loss
January through December 2018

	<u>Jan - Dec 18</u>
Total B. Home Delivery	24,473.44
C. Outreach	
Bus Maint., Insurance, Expenses	702.84
Gas & Oil	291.52
Worker's Comp.	185.04
C. Outreach - Other	153.67
Total C. Outreach	1,333.07
D. General	
Bus Maintenance, Insurance Exp.	260.64
Custodian	1,620.00
Fund Raiser	
Bakery	256.04
Crafts/Raffles	19.33
General	58.14
Pancake Breakfast	412.68
Pop	148.49
Fund Raiser - Other	100.00
Total Fund Raiser	994.68
Gas and Oil	171.30
Insurance	119.86
Miscellaneous	
Advertising/Newsletter	402.44
Bingo	129.38
Laundry	39.75
Misc.	538.63
Professional Services	15,825.00
Sales Tax	507.48
Training	228.15
Miscellaneous - Other	515.67
Total Miscellaneous	18,186.50
New Equipment	726.81
Raw Food	3,700.60
Repairs	1,078.60
Supplies	
Office	319.66
Supplies - Other	942.95
Total Supplies	1,262.61
Utilities	2,251.95
Worker's Comp	411.20
D. General - Other	0.00
Total D. General	30,784.75
E. Payroll Expenses	
Holiday	1,737.47

4:10 PM
02/19/20
Cash Basis

Shelley Area Senior Citizens, Inc.
Profit & Loss
January through December 2018

	<u>Jan - Dec 18</u>
Hourly	45,877.44
Officer Salary	17,963.79
Sick Pay	173.88
Taxes	
Medicare	964.02
Social Security	4,122.04
Total Taxes	<u>5,086.06</u>
Vacation	731.88
E. Payroll Expenses - Other	<u>88.50</u>
Total E. Payroll Expenses	<u>71,659.02</u>
Total Expense	<u>166,604.85</u>
Net Ordinary Income	1,065.90
Other Income/Expense	
Other Income	
Interest Income	<u>8.11</u>
Total Other Income	<u>8.11</u>
Net Other Income	<u>8.11</u>
Net Income	<u><u>1,074.01</u></u>

Shelley Area Senior Citizens, Inc.
Profit & Loss
 January through December 2019

	Jan - Dec 19
Ordinary Income/Expense	
Income	
A. Congregate - Revenue	
Title	17,331.00
USDA	10,538.61
A. Congregate - Revenue - Other	25,623.17
Total A. Congregate - Revenue	53,492.78
B. Home Delivery - Revenue	
Title	15,787.50
B. Home Delivery - Revenue - Other	9,665.00
Total B. Home Delivery - Revenue	25,452.50
C. Outreach - Revenue	
General/Doctor Trips	884.00
Total C. Outreach - Revenue	884.00
C. Transportation - Revenue	
General Fund Raiser	46.00
Total C. Transportation - Revenue	46.00
D. General - Revenue	
City/County	30,000.00
Donations	
\$5-20 Dollar A Month Donations	5,853.55
United Way	
Donor pledges received	2,102.43
Grants- UW	4,369.87
Total United Way	6,472.30
Donations - Other	1,564.00
Total Donations	13,889.85
Fund Raiser	
Bakery	658.00
Building Rental	1,516.50
Chuck-A-Rama Cards	125.00
Crafts	95.00
Pop Sales	299.00
Fund Raiser - Other	3,821.24
Total Fund Raiser	6,514.74
General	
Catered Meal Income	1,653.00
Misc Income	1,610.00
Unrealized gain/loss	-2,178.49
Total General	1,084.51

Shelley Area Senior Citizens, Inc.
Profit & Loss
January through December 2019

	<u>Jan - Dec 19</u>
D. General - Revenue - Other	4,618.12
Total D. General - Revenue	<u>56,107.22</u>
Total Income	135,982.50
Expense	
A. Congregate	
Custodian	3,906.00
Insurance	907.20
Miscellaneous	
Advertising/Newsletter	618.84
Laundry	278.25
Misc.	140.16
Total Miscellaneous	<u>1,037.25</u>
New Equipment	2,398.11
Raw Food	15,938.11
Repairs	5,023.70
Supplies	
Office	528.47
Supplies - Other	1,000.85
Total Supplies	<u>1,529.32</u>
Utilities	4,807.67
Worker's Comp	1,519.51
Total A. Congregate	<u>37,066.87</u>
B. Home Delivery	
Insurance	278.53
Mileage	3,098.22
Miscellaneous	
Advertising/Newsletter	176.81
Laundry	79.50
Misc.	42.56
Total Miscellaneous	<u>298.87</u>
New Equipment	456.79
Raw Food	10,945.74
Repairs	1,622.29
Supplies	
Office	507.51
Supplies - Other	2,492.83
Total Supplies	<u>3,000.34</u>
Utilities	1,243.37

Shelley Area Senior Citizens, Inc.

02/19/20

Profit & Loss

Cash Basis

January through December 2019

	Jan - Dec 19
Worker's Comp	516.06
Total B. Home Delivery	21,460.21
C. Outreach	
Bus Maint., Insurance, Expenses	1,307.02
Gas & Oil	218.38
Worker's Comp.	258.03
C. Outreach - Other	23.10
Total C. Outreach	1,806.53
D. General	
Bus Maintenance, Insurance Exp.	497.10
Custodian	1,674.00
Fund Raiser	
Bakery	60.68
General	649.75
Pancake Breakfast	172.96
Pop	210.12
Fund Raiser - Other	60.00
Total Fund Raiser	1,153.51
Gas and Oil	89.20
Insurance	434.27
Miscellaneous	
Advertising/Newsletter	107.05
Bingo	145.86
Laundry	39.75
Misc.	1,765.55
Professional Services	940.00
Sales Tax	465.94
Training	84.52
Miscellaneous - Other	457.41
Total Miscellaneous	4,006.08
New Equipment	951.62
Raw Food	4,175.59
Repairs	1,689.49
Supplies	
Office	394.26
Supplies - Other	926.11
Total Supplies	1,320.37
Utilities	2,238.09
Worker's Comp	573.40
Total D. General	18,802.72
E. Payroll Expenses	
Holiday	2,019.43

4:09 PM
02/19/20
Cash Basis

Shelley Area Senior Citizens, Inc.
Profit & Loss
January through December 2019

	<u>Jan - Dec 19</u>
Hourly	52,234.76
Officer Salary	17,984.66
Sick Pay	418.78
Taxes	
Medicare	1,066.95
Social Security	4,562.12
Total Taxes	5,629.07
Vacation	925.00
E. Payroll Expenses - Other	112.50
Total E. Payroll Expenses	79,324.20
Total Expense	158,460.53
Net Ordinary Income	-22,478.03
Other Income/Expense	
Other Income	
Interest Income	7.04
Total Other Income	7.04
Net Other Income	7.04
Net Income	<u><u>-22,470.99</u></u>

EXHIBIT EIGHT: Letters of Support

Scott Reese,
Emergency Management for
Bingham County
Dale Clark,
Hobbs Middle School Principal
Heather Bjornlie,
ISU Student & Volunteer
Mike Spencer,
American Legion Post 93
Elias Lopez,
District Director of the Grand Teton
Council of the Boy Scouts of America



BINGHAM COUNTY SHERIFF

Craig T. Rowland, *Sheriff*

Jeff Gardner, *Chief Deputy*

January 16, 2020

Sharon Deal
Community Development Specialist
Idaho Department of Commerce
P.O. Box 83720
Boise, ID 83720-0093

Dear Ms. Deal,

As the Bingham County Emergency Management Director, I support the Idaho Community Development Block Grant being submitted on behalf of the City of Shelley, for improvements to the Shelley Senior Center. This is a great candidate to receive these funds.

The Shelley Senior Center is a known location for seniors in the area, to receive meals and education, so, in the event of an emergency; they would be familiar with the location. The upgrades to the kitchen, the addition of a shower in the restroom, and the placement of a generator will prepare the Shelley Senior Center to become an emergency shelter for vulnerable adults in the area. Once again, I am fully in support of this project.

V/R

A handwritten signature in blue ink that reads 'R. Scott Reese'.

R. Scott Reese
Emergency Management Director
Bingham County

Dale Clark
Principal

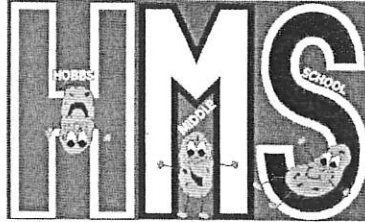

Hobbs Middle School
Joint School Dist. #60

February 26th, 2020

To Whom it may concern;

My name is Dale Clark, I am the Principal at Hobbs Middle School. 4 years ago I approached Dennie Long and the Shelley Senior Center about bringing 4 kids each Wednesday to do a community service project of helping server and clean up at the Senior lunch on Wednesdays. Our students need to be taught how it feels good to help others and this has been a very worthy cause. I pick 1 student and they get to pick 3 friends and we get permission slips from parents to attend this service project. I try to only let each student do this one time in their years at Hobbs, but sometimes kids bug me so much that I let them do it 2 times. I have never had a kid say they hate doing it and in fact I have kids all the time say they love it and want to do it again. I also get tons of seniors saying how much they appreciate me bringing kids for both the kids experience but it also does their heart good to see young kids serving them. When the kids get there they are introduced and the seniors always give them a big applause. The kids then deliver trays of food to the seniors so there is some good interactions between youth and elderly. After the seniors eat the kids pick up the trays and empty them into garbage cans.

This is such a win win for both my students and the senior center. I hope we are able to continue this community service project for many years to come.

Dale Clark
Hobbs Middle School Principal

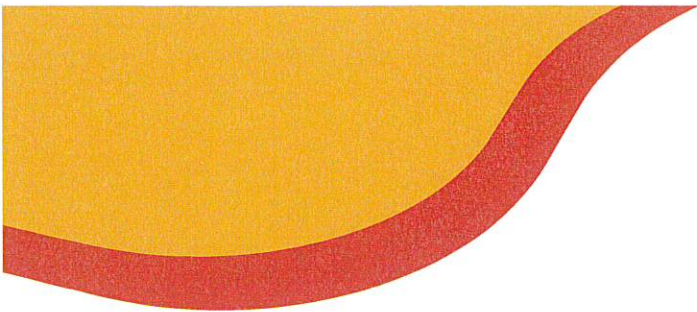

214 E. Center St #B, Pocatello, ID, 83201

208-233-4032

amanda@sicog.org

Amanda,

I am writing to SICOG in reference to the Elite Retreat Senior Center of Shelley, Idaho. My name is Heather Bjornlie, and I have been volunteering weekly at the center by teaching art classes for a little over a year. I wanted to take a moment to highlight the importance of this center through observations from my classes, in order to help the center in obtaining a well-deserved grant.

The members of the Elite Retreat have opportunities for socialization, education, and health benefits at the center on a weekly basis. I have seen many members benefit from the meals when they don't feel like cooking. Or get help with their taxes when they don't have the money to pay a company to do it. The members can get involved with local and out of state field trips. They also have the chance to take classes to improve their health; like having a nurse trim their toe nails since they have a hard time bending over, or participating in fall proof classes. The center also has food delivery services, and services to give rides to people around town who need a lift.

With all these benefits, it is imperative that the employees running the Elite Retreat have access to everything they need to provide for the seniors in our community. In just my classes I have seen the upmost gratitude from the ladies who attend. They have commented on how the art lessons have helped give them something to look forward to doing on a daily basis. They often come back to class as giddy as school kids when they show me the pieces they worked on throughout the week. My class is just one important cog in the whole operation of the center. And the center plays a huge role in the health overall of our small community of Shelley.

Warm regards,



Heather Bjornlie



618 W. Fir Street Apt G 202, Shelley, Idaho, 83274

208-227-3296

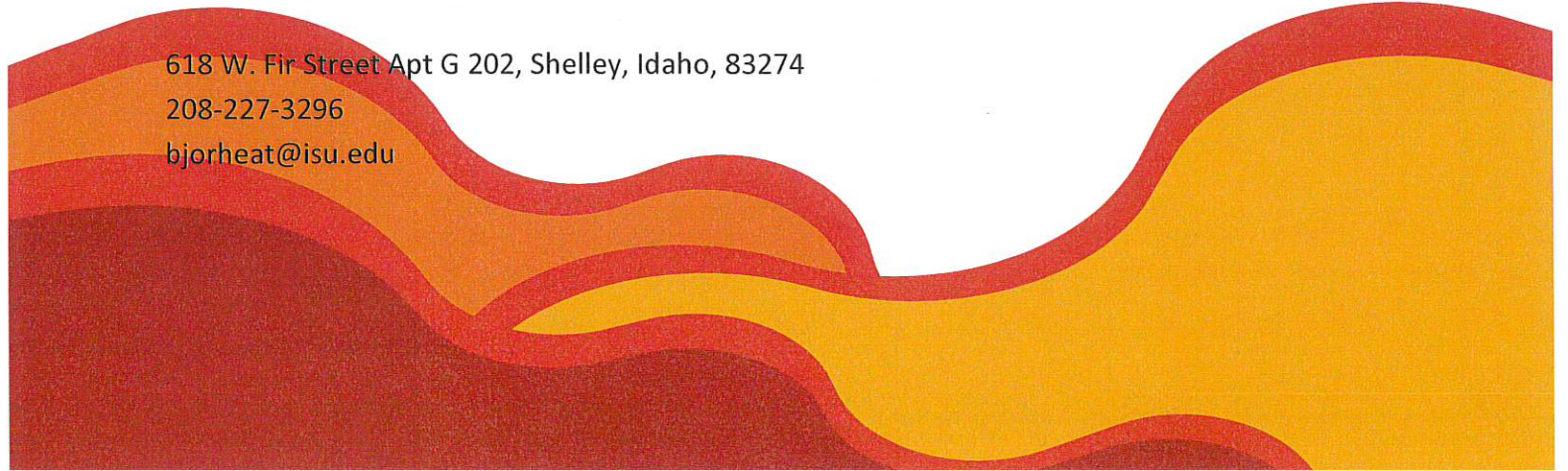
bjorheat@isu.edu



David B. Bleak

Post



93

Shelley, Idaho

February 14, 2020

LTR 2020-1

Sharon Deal
Senior Community Development Specialist
Idaho Commerce
700 W. State Street
Boise, ID 83702

Subject: Shelley Senior Center Grant

At the 1/14/2020 Shelley City Counsel meeting you made a presentation regarding a grant application for Phase II renovation to Shelley Senior Center. The David B. Bleak Post 93 of the American Legion supports this grant. The Post uses this facility for monthly meetings and a method to inform the lunch crowd of upcoming Post sponsored activities.

Thank you,

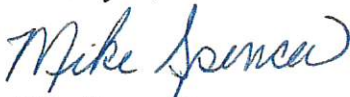

Mike Spencer

Adjutant

CC:

Amanda Collins
214 E Center St.
Pocatello, ID 83205



BOY SCOUTS OF AMERICA®
GRAND TETON COUNCIL

February 25, 2020

Dear Department of Commerce.

On behalf of the Grand Teton Council-Boy Scouts of America, we are very grateful for the use of the Shelley Senior Center for our Scouting purposes at no charge! Since we no longer have sponsorship of Scout units with the Church of Jesus Christ of Latter-Day Saints, it has been a challenge to find meeting locations for our youth groups to meet.

Since there is a Cub Scout Pack and a Scout Troop meeting in their building, that has provided a valuable resource for many families to be a part of our youth organization that help teach Character Development, Citizenship and Personal Fitness through living the Scout Oath and Law in their everyday lives. The use of the facility is a great help for the two groups and their families to hold their meetings weekly. This usually would incur a cost of \$50.00 each time the Scout groups would use this and that would be very difficult for them to pay this with limited funds.

With your consideration and our gratitude to the Shelley Senior Center, please accept our support letter to help convince your committee board to accept their request for your generous grant to serve their needs.

Sincerely,

Elias Lopez | District Director



GRAND TETON COUNCIL
BOY SCOUTS OF AMERICA

3910 So. Yellowstone Hwy. Idaho Falls, ID 83402
Work: 208.522.5155 | Cell: 208.716-9363 | Fax: 208.522.5158
elias.lopez@scouting.org | www.tetonscouts.org

